



OPERATING MANUAL

AUTOMATIC SPRAY GUN CLEANERS UG7500 SERIES

PATENTS

U.S.A.	4,785,836	CANADA	1293909
U.S.A.	5,213,117	ENGLAND	EP 0300248 (UK)
EUROPE	0300248	ITALY	69760/BE/92
SWEDEN	0300248	GERMANY	DE 38 75 412
FRANCE	8110528.0	JAPAN	1-302098

UNI-RAM CORPORATION • ONTARIO • CANADA

CONTENTS

INTRODUCTION	3
CAUTIONS AND WARNINGS	3
FEATURES AND OPTION COMPARISON	3
STRUCTURE OF SPRAY GUN CLEANERS	4
SETUP	
INSPECTION	5
LOCATION	5
LEVELING, VENT AND AIR SUPPLY	5
SOLVENT SELECTION	5
SOLVENT PAIL SETUP	6
GROUND WIRE INSTALLATION	7
OPERATION	
PRE - CLEAN	7
CLEANING SPRAY GUNS AND CUPS	7-8
USING THE MANUAL WASH and RINSE	8
SPRAY GUN TESTING	8
HOSE CLEANING (FACTORY OPTION)	8
AFTER CLEANING	8
CONNECTING TO A SOLVENT RECYCLER	8
DAILY MAINTENANCE	
FILTER PADS AND SCREEN	9
REPLACING SOLVENT	9
TROUBLESHOOTING CHART	10-11
TROUBLESHOOTING PROCEDURES	12-13
FLOW DIAGRAMS	14 & 17
REPLACEMENT PARTS	15
ACCESSORIES, OPTIONS AND CONSUMABLES	18
WARRANTY	
EXTENDED WARRANTIES For North American Customers	18
FULL PRODUCT WARRANTY	19

INTRODUCTION

Uni-ram holds many patents on designs used in its innovative products. Every machine is rigorously tested for compliance with stringent Quality Assurance standards. Follow the directions in this manual under Setup, Operation and Maintenance in order to operate this machine safely and effectively. Not following these instruction can lead to malfunction or damage to the machine. Follow directions under the section below, **Cautions and Warnings**, and on labels attached to the machine. Ensure that the manual is readily available for the operator at all times. If you have any questions about the operation of this machine, call your distributor or a Uni-Ram Service Engineer.

**North America:
Uni-ram Technical Service
1-800-417- 9133
Other Continents:
Contact Your Supplier**

CAUTIONS AND WARNINGS

- Always disconnect this machine from power sources before performing maintenance
- Do not smoke or use near open flames, sparks or heat.
- Ground pails and cabinet using supplied grounding wires

FEATURE AND OPTION COMPARISON

Basic UG7500 Model has the following features

- Auto Wash, Clean rinse and air purge
- Manual Wash - Brush and Rinse - Flexible Spigot
- Three Diaphragm Pumps and Rinse Pumps
- Hand free - Foot pedal Operation
- Manual and Automatic Fume extraction
- Clean 2 Guns and 2 Cups (2 Nozzles and 14 Jets)
- Hood - Stainless Steel

FEATURE	MODEL					
	UG7500	UG7500A	UG7500E	UG7500LE	UG7500SE	UG7500NG**
BASE CABINET	PAINTED	PAINTED	PAINTED	PAINTED	STAINLESS STEEL	PAINTED
2-PAIL SET, W/O RAISER & OVERFLOW	N/A	INCLUDED	N/A	N/A	N/A	INCLUDED
2-PAIL SET, KIT, INCL. HOSES & FITTINGS	N/A	N/A	INCLUDED	INCLUDED	INCLUDED	N/A
REMOVABLE VAPOUR FILTER	N/A	N/A	N/A	INCLUDED	N/A	N/A
BUILT-IN SPRAY TESTING SYSTEM	N/A	N/A	N/A	INCLUDED	N/A	N/A
FOLDING HOOD DOOR	N/A	N/A	INCLUDED	INCLUDED	INCLUDED	INCLUDED
HOSE CLEANING	OPTIONAL	OPTIONAL	OPTIONAL	OPTIONAL	OPTIONAL	NA
SHIP WEIGHT	70 lbs (31.8 Kg.)					
SHIP SIZE W x D x H	70"x30"x60" (178cm x76cm x152cm)					

** The UG7500NG does not have a Automatic Cleaning Tank and is specialized for Manual Wash and Rinse:only.

STRUCTURE AND KEY COMPONENTS

(For "NG" model, se page 16)

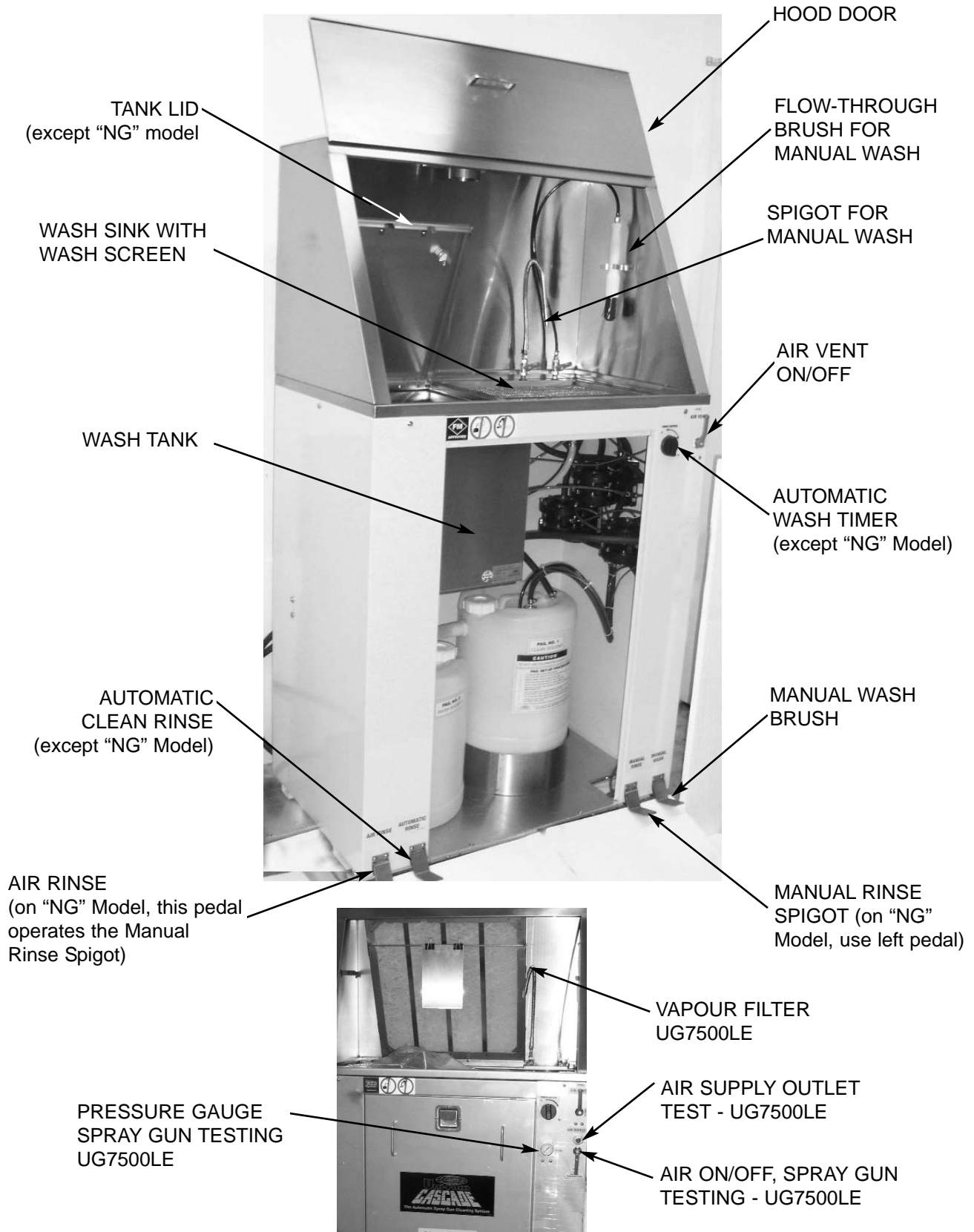

SETUP

INSPECTION

- Inspect the shipping carton for signs of damage. It is your responsibility to report damage to the transport company. Uni-ram Corporation does not accept responsibility for shipping damage once the machine has left our warehouse. Keep the packaging materials until you are sure the machine has not been damaged during shipping.
- Remove the machine from the carton by opening the bottom flaps and sliding the carton up over the machine.
- Make sure the bag of accessories contains the following:
 - Manual
 - Kit - Plug, Guns W.Trigger Lock Springs, 2 pieces (Part No. 140-2340)
 - Moisture Filter (Part No. 10-220)
 - Nozzle Adapters, 1 each of 2 kinds (Part No. 110-430 and 110-430L1P)
(Part number for optional mini adapter is 110-430MJP)
 - Hood Door Support (Part No. 780-3723)
- Remove the protective covers on all the outlets.
If any items are missing, contact your supplier.

LOCATION

Position in a well-ventilated area away from sparks, heat and open flames.

LEVELING, VENT AND AIR SUPPLY

- Level the machine using the adjustable legs.
- Attach a vent hose (not supplied) to the vent outlet on top of the machine. The duct system must not be under continuous vacuum.
- Attach an air supply adapter (not supplied) to Air Inlet Fitting (see right).

The air supply pressure must be at least 85 PSI and the air must be free from contaminants such as water, dust, rust, tar, grease etc.

To prevent damage to the Diaphragm Pump an internal Air Pressure Regulator has been installed to limit the air pressure to precisely 85 PSI. Do not install a second air pressure regulator or use a pressure set below 85 PSI.

See the section, Daily Maintenance, for proper maintenance of the Air Filter Assembly.



SOLVENT SELECTION

The adhesion quality of automotive paint has dramatically improved in recent years. The choice of solvent is critical. Use only good quality solvent that is formulated for your paint and intended for use with automatic spray guns cleaners.

SOLVENT PAIL SETUP

- Remove the door of the base cabinet
- Move the Drain Valve handle to the "open" (vertical) position if it is not already there. See picture.
- Two 5-Gal (19 L) pails of solvent are required, one full and one containing 3 Gal. Place the pails in front of the machine, full pail on the right and the other pail on the left.
- Inside the cabinet you will see two pipes strapped together, the Suction Pipe and the Rinse Pump. Cut the strap holding them together. **Do not cut** the other straps holding the black and blue tubes.
- Disconnect the Suction Pipe from the Drain Valve by pushing the gray button and bring both pipes outside of the cabinet.
- Insert the Rinse Pump into the full pail on the right and the Suction Pipe into the pail with 3 gal on the left. Insert the Manual Wash Suction Tube into the lid of the left (wash) pail, as shown. Insert the Manual Rinse Suction Tube through the lid of the right (rinse) pail, as shown.
- Move the pails into the cabinet and re-connect the Suction Pipe of the left pail to the Drain Valve.

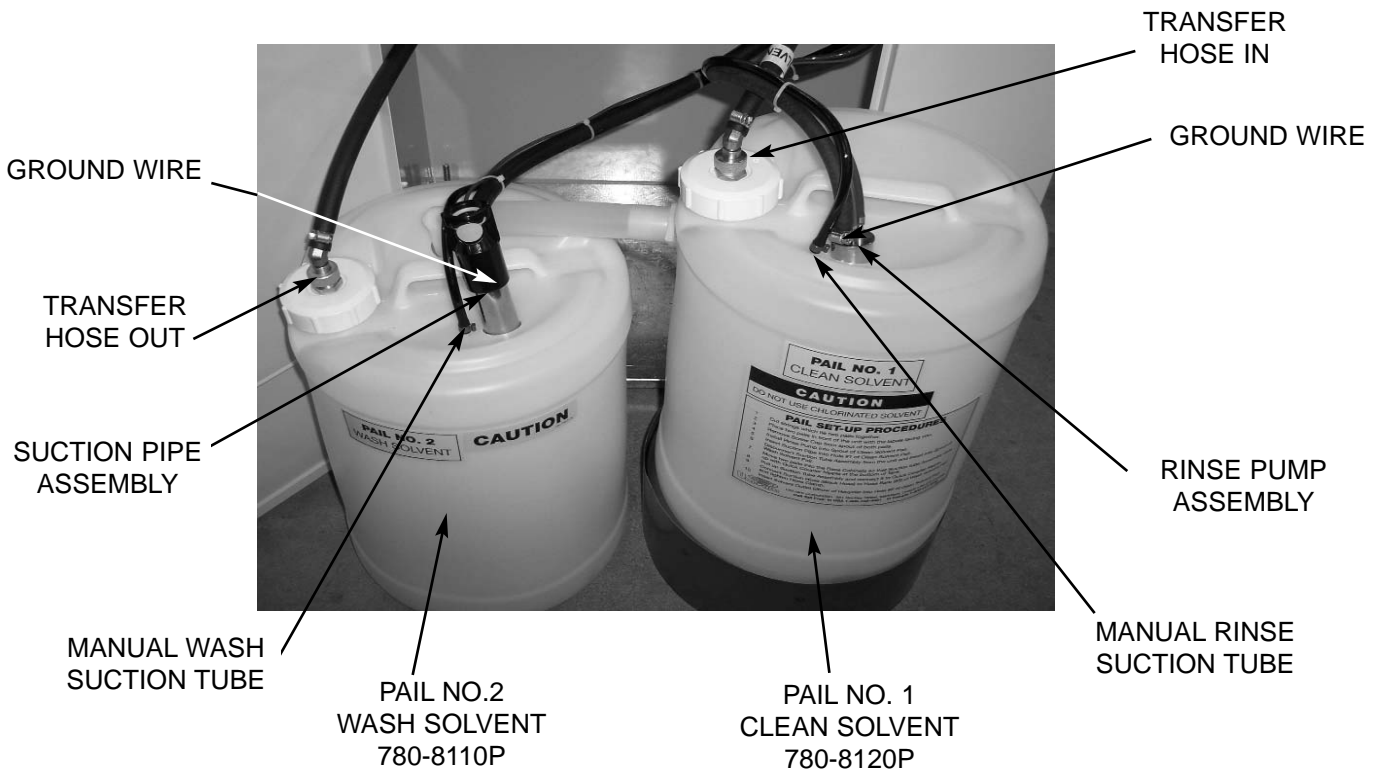
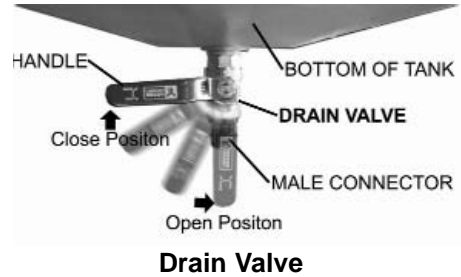

Note: The "NG" model has a Stainless Steel Pail Set, see page 16.

GROUND WIRE INSTALLATION

- Three ground wires are provided to discharge static electricity. To work properly, all three must be installed correctly. Connect the two ground wires inside the cabinet to Suction Pipe and to Rinse Pump and the wire on the outside back of the cabinet to an external grounded object.

OPERATION

PRE - CLEAN

- Disconnect the spray gun from the air hose. Pour paint from the cup (when present) into a 5 gallon pail (not supplied).
- Rinse cup with solvent and pour into the same 5 gallon pail for later disposal or recycling.

CLEANING SPRAY GUNS AND CUPS

- Loosen the air cap of the spray gun two full turns.
- Lock the trigger in the open position with the Trigger Lock Spring.

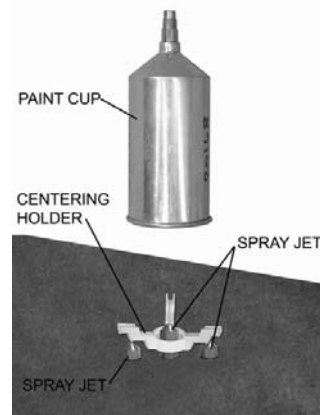
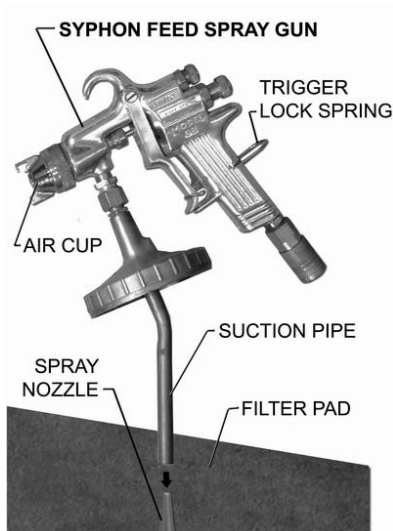
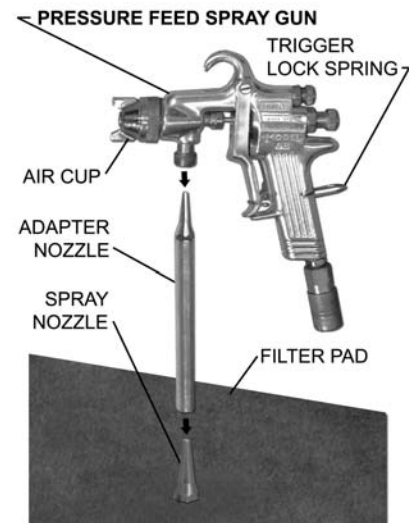

- Plug air inlet of spray gun with cap to prevent solvent from entering passage. Caps are supplied in the accessory kit.

CLEANING SPRAY GUNS AND CUPS (except for “NG” model)

- Place spray guns facing corner jets. Placement depends on **type of spray gun**. See pictures. Place cups onto the low spray jets and cup holders.
- Close the lid and turn the “Auto Wash Timer” knob clockwise to start cleaning. The cleaning takes about 60seconds
- Push and hold the "Air Rinse" button for about 3 second to air-rinse the guns.
- Push and hold the "Clean Rinse" button for about 5 seconds to rinse guns with clean solvent. This will send a pre-set amount of clean solvent (100 cc) through the jets. Wait 30 seconds for the Rinse Pump to fully recharge before repeating.

The solvent flow per clean-rinse cycle is limited to 100 cc to minimize consumption. This quantity is usually sufficient to clean the inside pasages of the spray guns.

USING THE MANUAL WASH and RINSE

Manual Wash Brush (used solvent)

- Step on the manual wash pedal. A dedicated pump delivers wash (used) solvent through the brush.

Manual Rinse Spigot (clean solvent)

- Step on the manual rinse pedal. Clean solvent is delivered through the spigot.

SPRAY GUN TESTING - LE model only (see picture on page 4 or 14)

- Connect the Spray Gun to the Air Supply Outlet and turn on the Air using the Air On/Off lever.
- Check the air pressure on the Pressure Gauge. Using the Pressure Regulator (inside the cabinet on the right), adjust the pressure according to the requirements of the Gun (pre-set value is 15-25 PSI).
- Test the Gun and turn off the Air when finished.

HOSE CLEANING - FACTORY OPTION (except “NG” model))

- This feature can be used to clean a paint feeder hose up to 100 feet (30 m) long. Connect the hose to the two fittings, one on the front and one on the right side. Rotate the "Mode Selector" handle to the horizontal position and turn the Timer knob clockwise to start the automatic cleaning cycle.

AFTER CLEANING

- Remove the guns and cups from the tank and wipe them dry. Do not store spray guns in the tank.

CONNECTING TO A SOLVENT RECYCLER

- On the back of the machine, connect the Transfer Hoses to the Solvent-In and Solvent-Out connectors.

DAILY MAINTENANCE

FILTER PADS AND SCREEN

- Inspect the filter pad in the bottom of the cleaning tank and, if there is a build up of paint debris, clean the pad by removing it from the tank and washing away the paint debris.

REPLACING SOLVENT

- Disconnect the Suction Pipe from the Drain Valve and remove the pipe from the pail. Move the pail out of the cabinet and recycle or dispose of the dirty wash solvent.
- Place a new, full-pail of clean solvent in front of the cabinet.
- Move the pail into the cabinet and re-connect the Suction Pipe to the Drain Valve.

TROUBLESHOOTING CHART - UG7500 SERIES

SYMPTOM	REASON	CORRECTIVE ACTION
WASH SOLVENT DOES NOT FLOW AND PUMP MAKES A PUMPING NOISE	• Drain valve closed	Open drain valve (put in verticle position), if not already open • Check wash solvent level. Add solvent if less than 1/2 full.
	• Solvent level too low	• Check wash solvent level. Add solvent if less than 1/2 full
	• Paint debris in pump	Follow Procedure 1, "Blocked Fluid Passage in Diaphragm Pump"
	• Blockage in solvent line	• Follow Procedure 4, "Blocked Passage in Solvent Line"
WASH SOLVENT DOES NOT FLOW AND PUMP MAKES A HISSING NOISE	• Water in air line causes pump to stall	• Follow Procedure 2, "Blockage in Air Passage in Diaphragm Pump"
WASH SOLVENT DOES NOT FLOW AND PUMP DOES NOT MAKE A NOISE	• Pump leaks	• Replace pump
	• Blockage in air passage	• Follow Procedure 3, "Blocked Passage in Air Line".
PUMP DOES NOT STOP UNLESS TIMER IS TURNED BY HAND OR AIR IS SHUT OFF	• Defective Timer	Follow Procedure 1, "Blocked Fluid Passage in Diaphragm Pump"
TIMER KNOB SPINS BACK WHEN TURNED	• Defective Timer	• Follow Procedure 4, "Blocked Passage in Solvent Line"
INSIDE WALL OF TANK IS COATED WITH PAINT EVEN THOUGH OPERATOR MAINTAINS TANK	• Solvent lacks cleaning strength	Replace solvent with solvent that is formulated for type of paint used • and for use with automatic spray gun cleaning
GUNS NOT CLEAN, PUMP WORKING, SOLVENT FLOW NORMAL	• Trigger not locked in open position	• Use Trigger Lock Spring
GUNS NOT CLEAN, WASH SOLVENT IS MILKY WHITE	• Spray gun is not properly installed onto nozzle	• Re-install with proper adapter
	• Incompatible solvent	Replace incompatible solvent with solvent formulated for the type of paint used and for Automatic Spray Gun Cleaners.
	• Low pressure in air supply	• Increase air pressure to a minimum of 85 PSI
	• Plugged jets	Remove and clean by blowing air through the jets. If not successful, replace.
GUNS NOT CLEAN, WASH SOLVENT IS MILKY WHITE	• Wash solvent is contaminated with water	• Replace or recycle wash solvent

...continued next page

TROUBLESHOOTING CHART - UG7500 SERIES ... continued

SYMPTOM	REASON	CORRECTIVE ACTION
After Each Step Below, start the Timer. If solvent does not flow, carry out the next step.		
CLEANING PROBLEMS		
GUNS NOT CLEAN, PUMP WORKING, SOLVENT FLOW NORMAL	<ul style="list-style-type: none"> • Trigger not locked in open position 	<ul style="list-style-type: none"> • Use Trigger Lock Spring
GUNS NOT CLEAN, WASH SOLVENT IS MILKY WHITE	<ul style="list-style-type: none"> • Spray gun is not properly installed onto nozzle 	<ul style="list-style-type: none"> • Re-install with proper adapter
	<ul style="list-style-type: none"> • Incompatible solvent 	<ul style="list-style-type: none"> • Replace incompatible solvent with solvent formulated for the type of paint used and for Automatic Spray Gun Cleaners.
	<ul style="list-style-type: none"> • Low pressure in air supply 	<ul style="list-style-type: none"> • Increase air pressure to a minimum of 85 PSI
	<ul style="list-style-type: none"> • Plugged jets 	<ul style="list-style-type: none"> • Remove and clean by blowing air through the jets. If not successful, replace.
GUNS NOT CLEAN, WASH SOLVENT IS MILKY WHITE	<ul style="list-style-type: none"> • Wash solvent is contaminated with water 	<ul style="list-style-type: none"> • Replace or recycle wash solvent

TROUBLESHOOTING PROCEDURES

PROCEDURE 1

Blocked Fluid Passage In Diaphragm Pump

If the pump sounds like it is working but solvent does not flow, follow one of the procedures below to clear the fluid passage.

If you have a brass suction pipe:

- Disconnect the suction hose from the suction pipe and blow air at 85 PSI into the suction hose. See diagram. Turn timer. This procedure may have to be repeated several times. If this procedure does not help, blow some solvent into the suction hose using a spray gun, wait one minute and turn timer. This procedure may have to be repeated several times. If this procedure does not work, the pump must be replaced.

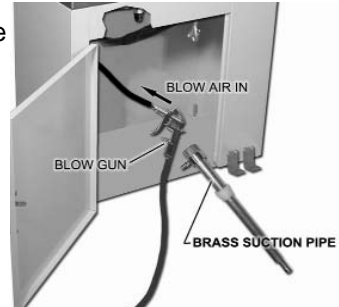

If you have a stainless steel suction pipe:

- Lift the suction pipe out of the solvent pail. See diagram. Blow air at 85 PSI into the bottom of the suction pipe. Turn timer. This procedure may have to be repeated several times. If this procedure does not help, blow some solvent into the suction hose using a spray gun, wait one minute and turn timer. This procedure may have to be repeated several times. If this procedure does not work, replace the pump.
- **Cause:** The check valve is stuck due to excessively contaminated solvent.
- **Preventative Action:** Remove debris from the filter pad and wash pad when there is excessive build up of paint debris. Replace the filter pad if damaged. Recycle or replace dirty solvent more often.



If you need to replace the pump call your local dealer. The warranty on the diaphragm pump is two years from date of purchase.

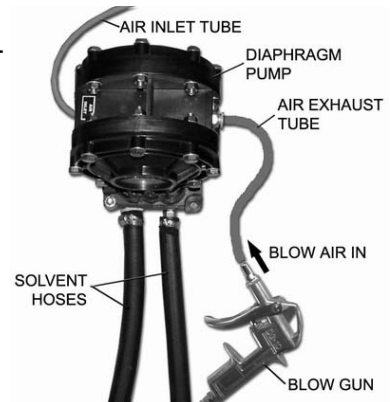

PROCEDURE 2

Blocked Air Passage In Diaphragm Pump

If there is a steady hissing sound and the pump is not cycling, the spool valve has stalled due to a blocked air passage. Follow the procedure below to clear the blockage.

- Connect a blow gun to an 80 PSI source. Locate the blue hose that extends from the air exhaust port of the diaphragm pump. Use a blow gun to blow air into the open end of this hose. Turn timer. If the procedure is successful, the pump will start working. The procedure may have to be repeated several times. If this procedure does not work, replace the pump.
- **Cause:** Contaminants in the air supply (water, oil, solid particles etc)
- **Preventative Action:** Drain liquid from the moisture filter. Install a Air Filter if one is absent.

TROUBLESHOOTING PROCEDURES

PROCEDURE 3

Blocked Passage in Air Line

The components in the air line are the **diaphragm pump, the auto wash timer, lid switch, regulator and air filter. See Flow diagram and section, Replacement Parts.**

To troubleshoot a component:

- 1) Disconnect the air line to the component using the quick disconnect.
- 2) Turn on the "Auto Wash Timer" and check for presence of positive air pressure in air line. If there is ample positive air pressure, replace the component.

If air pressure is absent, there is a faulty component upstream. Reconnect the air line and check the operation of the next component upstream by following steps 1 and 2 above.

PROCEDURE 4

Blocked Passage in Solvent Line

The components in the solvent line are: **suction pipe, diaphragm pump, combination valve, delivery tubes, jets. See Flow diagram and section, Replacement Parts.**

Troubleshoot Suction Pipe:

- 1) Disconnect Suction Pipe from drain valve and lift out of solvent pail.
- 2) Turn the "Auto Wash Timer" knob and check for suction by placing finger over end of the suction pipe.
- 3) If you feel suction, suction pipe is not faulty. If you do not feel suction, disconnect the hose to the inlet port on the diaphragm pump. If you feel suction, replace the suction pipe.

Troubleshoot Combination Valve:

- 1) Remove hose to the check valve, place end of hose in empty clean pail.
- 2) Turn the "Auto Wash Timer" knob and test for positive air pressure. If there is positive air pressure replace the combination valve.

FLOW DIAGRAM(S)

Use the diagram(s) to trace the flow of compressed air and solvent (see page 17 for the "NG" model).

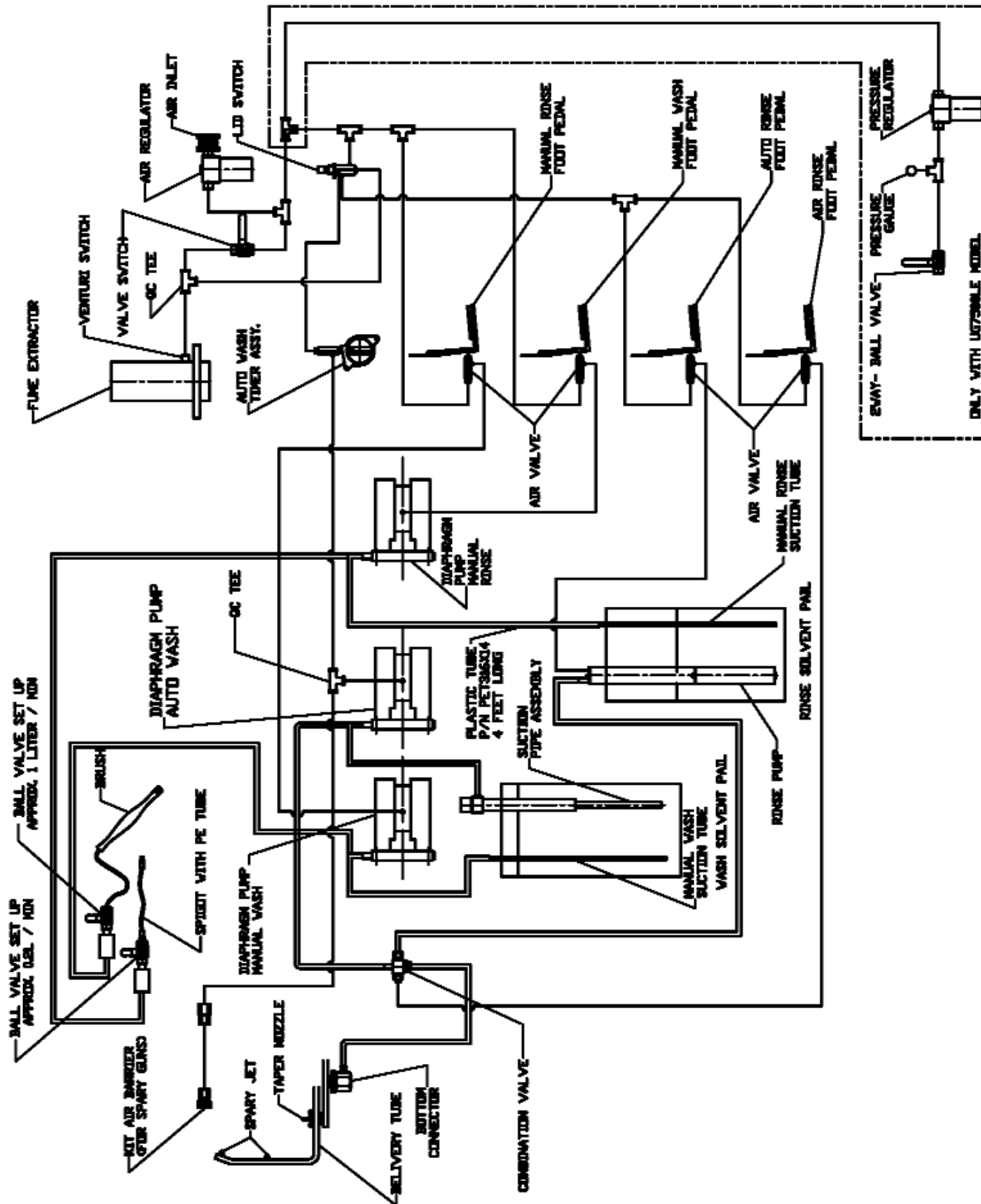

REPLACEMENT PARTS UG7500 SERIES
 (see page 16 for the "NG" model)

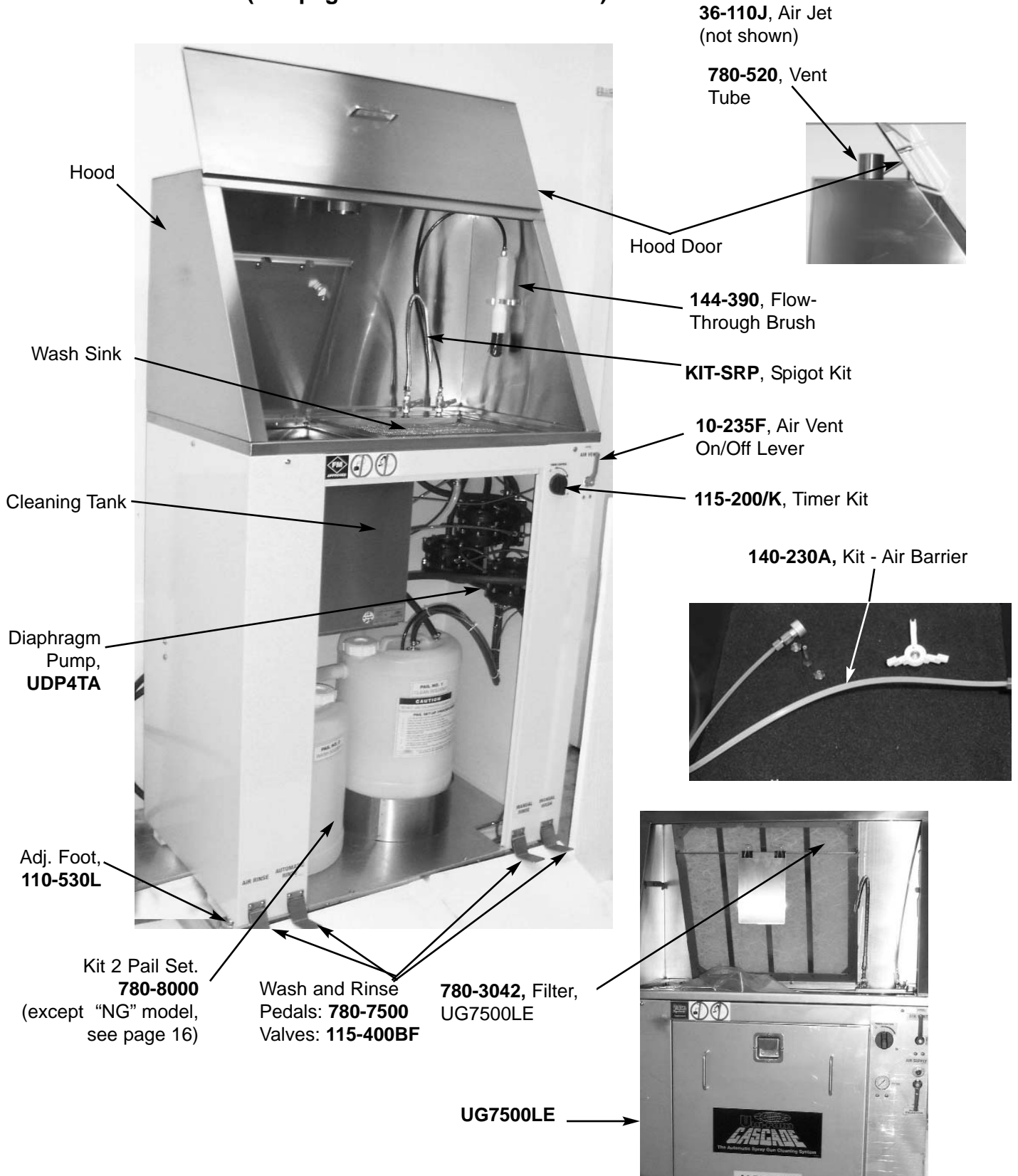

REPLACEMENT PARTS UG7500NG



144-390, Flow-Through Brush

KIT-SRP, Spigot Kit

Wash Sink with Screen Only (no Cleaning tank)

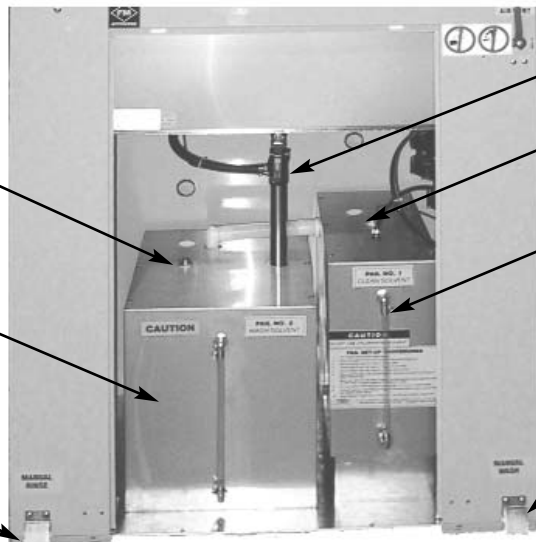

780-500, Suction Pipe

Connection for Solvent IN from Recycler

780-8220, Stainless Steel Rinse Pail

Manual Wash, Pedals: 780-7500 Valves: 115-400BF

Connection for Solvent IN from Recycler

Stainless Steel Wash Pail, 780-8230

Manual Rinse, Pedals: 780-7500 Valves: 115-400BF

FLOW DIAGRAM - UG7500NG ONLY

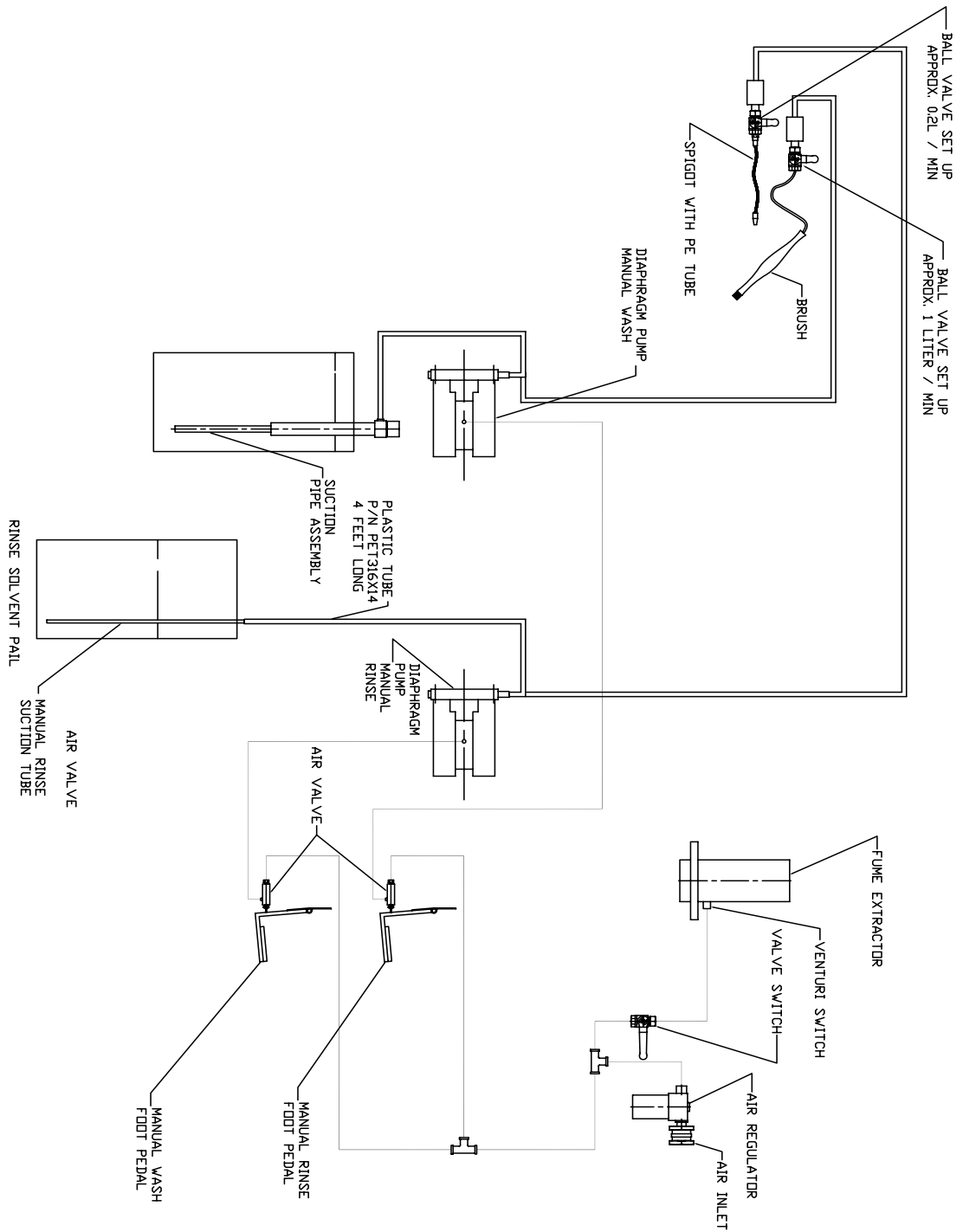

ACCESSORIES, OPTIONS AND CONSUMABLES

Model	Part No.	Description
Non "NG"	110-430	Nozzle Adapter, All models, Push On
Non "NG"	110-430SA	Nozzle Adapter, SATA, Mini Jet, Threaded
Non "NG"	110-430L1P	Nozzle Adapter, Push-On, SATA - 0.6 & 1.0 litre cups
Non "NG"	100-413F	Paint Cap Holder
Non "NG"	115-200/K	Mechanical Timer Assembly, 5 minutes
Non "NG"	140-340S	Rotating Spray Jet Assembly
All	100-835	Ground Wire for Gun Cleaner, 18G, Green, 4 FT
All	600-8901	Ground Wire for Pail
Non "NG"	780-8000	2-Pail Set required for connection to Solvent Recycler
Non "NG"	FP6500-10	Filter Pad, Pkg of 10
NG only	FP7500NG-1	Filter Pad, Single
All	UDP4TA	Diaphragm Pump

EXTENDED WARRANTIES For North American Customers

An extended warranty may be purchased within 3 months from the date of purchase. There are two types of warranty:

- 1) parts
- 2) parts and labour

The warranty period is 2, 3 or 4 years.

If you would like to purchase an extended warranty call Uni-ram at:

Canada	1-800-417-9133
USA	1-800-735-4331

Full Product Warranty



These Uni-ram products have been engineered and manufactured to high performance standards. Each unit has been subjected to detailed factory testing before shipment.

This product comes with a one-year full warranty from the date of purchase. Uni-ram Corporation reserves the right to repair or replace the unit, free of charge, to the original purchaser if a part is found to be defective in material or workmanship as determined by factory service personnel. The items listed below under "Conditions of Warranty" as consumables are not covered.

Uni-ram reserves the right to direct the customer to ship the unit collect to the Uni-ram factory or to an approved Service Center for repair using the Uni-ram Return Goods Procedure or to repair the unit on-site. To prevent damage in transport, the purchaser must ship the unit in the original packaging or use alternate adequate packaging. All units must be **shipped clean and free of solvent.**

Diaphragm Pump:

We are pleased to advise that the warranty on the diaphragm pump, the heart of the spray gun cleaner, comes with a 2 year replacement warranty. If, in the unlikely event your diaphragm pump fails during the first two years of service, call Uni-ram Service at 1-800-417-9133. We will send you a new pump free of charge and arrange for the return of your original pump.

Conditions of Warranty:

As Uni-ram Corporation has no control over the working conditions or circumstances under which the purchaser stores, handles or uses the product, Uni-ram makes no warranty or claim, either expressed or implied with respect to this product's fitness for any purpose or the result to be obtained from its use. This condition applies to the sale of all products and no representative or distributor of Uni-ram Corporation has the authority to waive or change these conditions.

This warranty applies only to the original purchaser and does not apply if the unit has been mis-used, overloaded, neglected, altered or used for any purpose other than those specified in the operating and installation instructions. Deterioration due to normal wear is not covered by this warranty. Damage due to accident, transportation, fire, floods or acts of God is also not covered. Units whose serial numbers have been altered or removed are not covered. The warranty is invalid if unauthorized chemicals as noted in the manual or solvents with acid content are used in this unit. Unauthorized attempts at self-repair or alterations by the owner also invalidate this warranty. Interior or exterior finishes are not covered by this warranty.

Consumable Items are not covered by this warranty (eg: gaskets, screens, bags, filters, nozzles and air jets).

This warranty replaces all other warranties expressed or implied by statute or otherwise.

To make a claim, call Uni-ram Service at 1-800-417-9133 and quote the serial number of the unit.