



USER MANUAL

RECLAIMING SAND BLASTERS

MODELS

UR007 UR007-YEXP

UR007-YJ



UNI-RAM CORPORATION • ONTARIO • CANADA

Revised 2010-03

CONTENTS

INTRODUCTION 3
CAUTIONS AND WARNINGS 3
PREPARATION 4
NOTES ON USE AND OPERATION 4
MAINTENANCE 5
TROUBLESHOOTING 5
FEATURES AND SPECIFICATIONS 5
REPLACEMENT PARTS 6
WARRANTY 7

INTRODUCTION

Uni-ram holds many patents on designs used in its innovative products. Every machine is rigorously tested for compliance with stringent Quality Assurance standards. Follow the notes on preparation, use and operation to operate this machine safely and effectively. Ensure that this manual is readily available to the operator at all times. If you have any questions about the operation of this machine, contact:

North America:
Uni-ram Technical Service
1-800-417- 9133
Other Continents:
Contact Your Supplier

CAUTIONS AND WARNINGS

- Wear safety glasses and follow all local safety regulations.
- Do not leave the unit unattended when plugged in. Unplug from outlet when not in use and before servicing.
- To reduce the risk of electric shock, do not use outdoors or near water or wet surfaces.
- Do not use with a damaged Power Cord or Plug. If the unit is not working as it should or if it has been dropped, damaged, left outdoors or emersed into water, contact Uni-ram for service instructions.
- Keep the Power Cord away from heat.
- Do not use without a filter.
- Turn off the Power Switch before unplugging.
- Use only a properly installed, grounded outlet.
- The filter is water resistant and washable in water. Do not use high pressure air or solvents to clean it. Cleaning with a soft brush is recommended.

PREPARATION

Note: Item numbers given below refer to the parts listing on page 6.

1. Check for transportation or handling damage.
2. Lay the carton on its side and wheel the unit out. Do not stand it back up until Step 9.
2. Make sure all parts and accessories are included.
3. Remove all packing material.
4. Remove the Vacuum Head Assembly and the Debris Container.
5. Remove the two items stored underneath the Debris Container during shipping: Tubular Handle, Gun+Head Assembly.
6. Install the Tubular Handle with the nuts and screws provided (see picture on Page 6).
7. Remove the Hose Assembly from the bag and insert the Abrasive Hose (the smaller of the two hoses), which protrudes past the Vacuum Hose, through the hole at the back of the unit. Connect it to the air outlet underneath the base of the unit.
8. Connect the Vacuum Hose to the connecting outlet on the container. Stand the unit back up.
9. Pour 20-40 LB (11-18 kg) of abrasive through the strainer at the bottom into the Abrasive Container underneath. It is not necessary to remove the strainer.
10. Connect the Vacuum Hose and Abrasive Hose to the Blast Head and the Air Line to the Blast Gun. Use the white clamp provided for the Abrasive Hose.
11. Re-insert the Debris Container.
12. Re-install the Vacuum Head and clamp in position.
13. When ready to operate, connect the Power Cord and turn on the Power Switch.

NOTES ON USE AND OPERATION

1. Use Air Pressure between 75 and 100 PSI depending on the surface to be cleaned.
2. Air Volume should be between 8 to 22 CFM (optimum: 16-20 CFM).
3. Use one hand to hold the Blast Gun and the other to hold the Blast Head as shown below.
4. Do not press downwards - the brush's function is to reduce the escape of abrasive and to maintain a vacuum for the efficient recycling of the abrasive.
5. Move both hands in the same direction.
6. The blast area may be varied by lengthening or shortening the nozzle with the Lock Bolt (Item 30, Page 6).
7. **Careful placement of the brush over the area to be cleaned is very important.** The bristles should be spread out so that the abrasive spray inside does not impact the bristles. This precaution will preserve the bristles, improve the vacuum effect, create better coverage and ultimately result in better savings, safety and results.
8. The flat 1-1/4" brush (Part No. 27-611) is supplied with the unit. Four additional specialty brushes are available. The same precautions should be followed when using these brushes.
9. When working on a 90° corner, align the gun at a 45° angle to reach the deepest area. Move the gun in a slow rotating motion for the best results.



**FILTER PART NO.
27-180 STANDARD
27-172 HEPA**

MAINTENANCE

1. After each use, knock the dust off the filter and after one hour of continuous use, lift off the Vacuum Head and check for dust accumulation. Clean the filter with a soft brush, vacuum or low-pressure air.

TROUBLESHOOTING

SYMPTOM	CAUSE AND REMEDY
Decrease in blast performance	Low air pressure. Check compressor and hose connections for leaks. Check CFM and PSI input.
	Moisture in the abrasive.
	The air supply must be clean and dry.
	Abrasive is worn or too fine and does not cut the surface.
	Vacuum Filter needs cleaning; debris collects with the media.
	Gun blockage. Disconnect air and power, unscrew nozzle, use a paper clip or thin wire to clear the passageway.
Decrease in vacuum performance	Filter needs cleaning.
	Check vacuum lines for blockage or leakage.
	Check CFM input.
Abrasive escapes from between bristles of brush	Air pressure is too high.
	Check vacuum lines for blockage or leakage.

FEATURES AND SPECIFICATIONS

Uni-ram Reclaiming Sand Blasters allow sandblasting without personal breathing apparatus, face masks or separate dust removal. The abrasive media are recovered and re-used continuously for a 92% reduction in media consumption.

- Can be used with most abrasives including:
 - glass beads, metal shot, aluminum oxide,
 - nut shells, plastic pearls, baking soda etc.
- Uses standard air fittings
- Air flow: 8-22 CFM
- Air pressure: variable to 150 PSI
- Fume grade filter standard, HEPA available
- Motor Speed: 19,600 RPM

MODEL	UR007	UR007-YEXP	UR007-YJ
POWER (V/W)	120/1350	240/1350	200/1350
STANDARD HOSE	8.5 FT (2.5m)	8.5 FT (2.5m)	8.5 FT (2.5m)
FILTRATION	CARTRIDGE	CARTRIDGE	CARTRIDGE
SHIP WEIGHT (LB/KG)	69/31	69/31	69/31
SHIP SIZE (WDH)	20X18X45"	20X18X45"	20X18X45"

REPLACEMENT PARTS

ITEM	PART NO.	DESCRIPTION
1	Z9852	Moulding, Head Cover
2	20-101-Y	Head Cover
3	27-100S	Vac Head Assy, Complete, 120V
4	110-313	Pull Handle
5	27-129*	Motor Brush
6	KIT-26123*	Vac Motor Kit, 1350W, 120V
6.1	KIT-26127*	Vac Motor Kit, 1350W, 240V
6.2	KIT-26125*	Vac Motor Kit, 1350W, 100V
6a	27-151	Valve Stem Assy for U5047
7	27-103	Gasket Motor Mount
8	27-131	Power Switch 120V
8.1	27-132	Power Switch 240V
9	27-141	Neon Lamp 100-120V
9.1	27-142	Neon Lamp 220V
10	27-112	Thermal Separator Plate
11	27-193	Vacuum Head Seal Gasket
12	27-218	Rim Clamp
13	27-180	Filter, Regular
13.1	27-172	HEPA Filter
14	25-215	Debris Container
15	27-217	Tubular Handle
16	27-710	Vacuum Hose Assy (8)
16.1	27-712	Vacuum Hose Assy (10 FT)
16+18	27-700	Complete Hose Assembly, 8'
17	27-721	Hose End Cuff, 1.5"
18	27-731	Abrasive Feeder Hose (8 FT)
18.1	27-732	Abrasive Feeder Hose (10 FT)
19	27-231	Abrasive Screen
20	Z123	Abrasive Screen Knob
21	11-161	Wheel, 6" Heavy Duty Industrial
22	27-381	Axle Shaft 1/2" x 18" ZP
23	27-384	Wheel Cap, High Impact, 1/2" Axle
24	27-378	Swivel Caster, 2" Wheel
25	20-250	Impeller Assembly
26	20-210-Y	Body Tube Assembly
27	U5047	Blast Gun Assembly
27+31	27-500	Blast Gun+Head (U5047+27-570)
28	51-252	Air Jet, 1/8" ID for Blast Guns
29	52-055	Steel Blast Nozzle
29.1	52-020	Ceramic Blast Nozzle
29.2	52-010	Carbide Blast Nozzle
30	27-513	Lock Bolt, 1/4" x 1/2"

ITEM	PART NO.	DESCRIPTION
31	27-570	Blast Head incl. Brush (27-611)
32	27-571	Blast Head without Brush
33	27-512	O Ring, D330
34	27-611	Flat Brush 1-1/4", Standard
34.1	27-612	Flat Brush 1-3/4", Optional
36	27-621	Inside Corner Brush (90° Male)
37	27-631	Outside Corner Brush (90° Female)
38	27-650	Brush and Holder (for thin edges)
	27-914	Abrasive, #60, 25 LB Pail
	51-270	Valve Stem Assy for U5047

* For units purchased before 2005-12, call before ordering

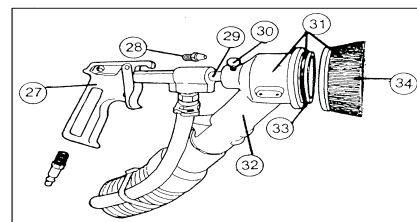
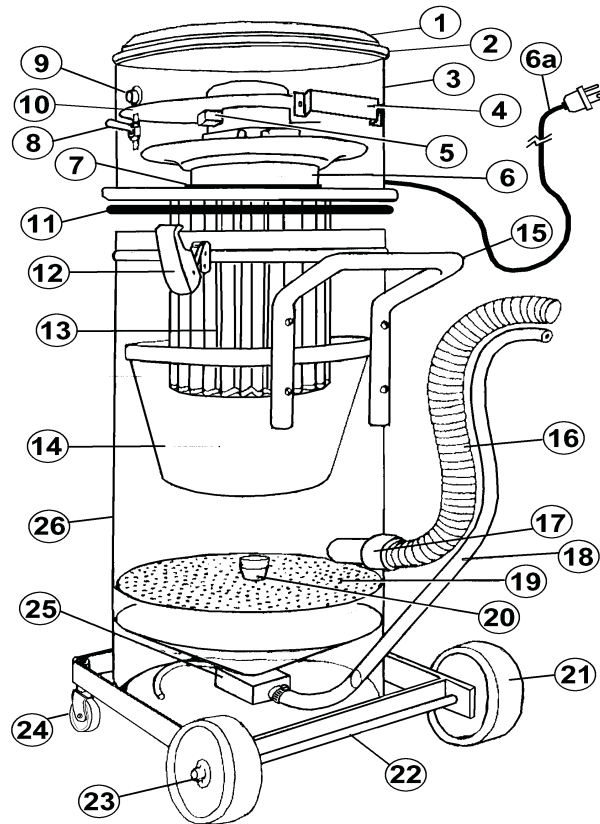

GUN + HEAD ASSEMBLY 27-500

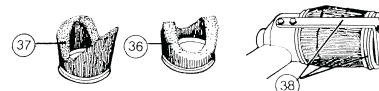

OPTIONAL BRUSHES

Full Product Warranty

These Uni-ram products have been engineered and manufactured to high performance standards. Each unit has been subjected to detailed factory testing before shipment.

This product comes with a one-year full warranty from the date of purchase. Uni-ram Corporation reserves the right to repair or replace the unit, free of charge, to the original purchaser if a part is found to be defective in material or workmanship as determined by factory service personnel. The items listed below under "Conditions of Warranty" as consumables are not covered.

Uni-ram reserves the right to direct the customer to ship the unit collect to the Uni-ram factory or to an approved Service Center for repair using the Uni-ram Return Goods Procedure or to repair the unit on-site. To prevent damage in transport, the purchaser must ship the unit in the original packaging or use alternate adequate packaging. All units must be shipped clean and free of solvent.

Conditions of Warranty:

As Uni-ram Corporation has no control over the working conditions or circumstances under which the purchaser stores, handles or uses the product, Uni-ram makes no warranty or claim, either expressed or implied with respect to this product's fitness for any purpose or the result to be obtained from its use. This condition applies to the sale of all products and no representative or distributor of Uni-ram Corporation has the authority to waive or change these conditions.

This warranty applies only to the original purchaser and does not apply if the unit has been misused, overloaded, neglected, altered or used for any purpose other than those specified in the operating and installation instructions. Deterioration due to normal wear is not covered by this warranty. Damage due to accident, transportation, fire, floods or acts of God is also not covered. Units whose serial numbers have been altered or removed are not covered. The warranty is invalid if unauthorized abrasives are used in this unit. Unauthorized attempts at self-repair or alterations by the owner also invalidate this warranty. Interior or exterior finishes are not covered by this warranty.

Consumable Items are not covered by this warranty.

This warranty replaces all other warranties expressed or implied by statute or otherwise.

To make a claim, call Uni-ram Service at 1-800-417-9133 and quote the serial number of the unit.

