

USER MANUAL

BB30N



UNI-RAM CORPORATION • ONTARIO • CANADA

CONTENTS

INTRODUCTION	3
CAUTIONS AND WARNINGS	3
FEATURES AND SPECIFICATIONS	4
SAFETY FEATURES	4
SOLVENT REQUIREMENTS AND DEFINITIONS	4
PREPARATION AND SETUP, INCLUDED PARTS, ADDITIONAL PARTS	5
LOCATION AND CONNECTION	5-6
OPERATING PROCEDURES	7-10
THEORY OF OPERATION	11
TROUBLESHOOTING GUIDE	12-13
TEST MODE	13
ERROR MESSAGES	14
SERVICE PROCEDURES INCLUDING 6-MONTH MAINTENANCE	15-16
REPLACEMENT PARTS	17-18
WARRANTY	19

INTRODUCTION

Uni-ram holds many patents on designs used in its innovative products. Every machine is tested for compliance with Quality Assurance standards. Follow the instructions on preparation, use and operation to operate this machine safely and effectively. Ensure that this manual is readily available to the operator at all times. If you have any questions about the operation of this machine, contact:

North America:
Uni-ram Technical Service
1-800-417- 9133
Other Continents:
Contact Your Supplier

CAUTIONS AND WARNINGS

- The operator should wear protective clothing in accordance with local safety and environmental regulations, with a minimum of face goggles and gloves along with an apron and respirator if required.
- Always disconnect the power source before performing maintenance.
- **DO NOT SMOKE OR USE THIS EQUIPMENT NEAR A POTENTIAL SOURCE OF IGNITION SUCH AS SPARKS OR AN OPEN FLAME.** This unit must be located at least 6 feet (1.8 m) from all potential sources of ignition including electrical receptacles, switches, pilot lights, fixtures and contacts when installed in a non - hazardous locations.
- The ambient temperature must be between 5°C (41°F) to 35°C (95°F).
- **DO NOT RECYCLE NITROCELLULOSE WHICH IS EXTREMELY VOLATILE. IT AUTOMATICALLY IGNITES AT 135 °C TO 166 °C (275°F TO 330 °F).** Do not install, operate or maintain this equipment where the auto ignition temperature of the solvent is lower than 250 °C (482°F).
- Do not install, operate or maintain this equipment where the auto ignition temperature of the hazardous atmosphere(s) is lower than 250 °C (482°F).
- Solvents that are recycled can be flammable. Establish and follow safe practices to store and handle solvents.
- Units must be installed by a qualified electrician.
- Install on a dedicated circuit with sufficient current capacity (see specifications section).

FEATURES AND SPECIFICATIONS

All Uni-ram Solvent Recyclers feature **rapid-start** direct electric heating of solvent and a **short cool-down time** due to high-efficiency condensers and air cooling with a motor driven fan.

SAFETY FEATURES

- This unit is certified under UL standard 2208 and CSA standards C22.2 No. 30 and No. 88 for use in non-hazardous locations as well as for use in hazardous locations Class 1, Division 1, Group D - T2C and Class 1, Division 2, Group D -T2C.
- **Explosion proof construction** and intrinsically safe electric circuitry.
- **Computer controlled** with many built-in safety programs including temperature control of all critical points including tank, condenser and fan motor.
- **Self Diagnostic** error messages are displayed on the Display Panel.
- **Dual lid** cover system.

Warranty: 1 year on unit, 2 years on pump.

SPECIFICATIONS

MODEL	BB30N
VOLTAGE (V)	220/240*
RECOMMENDED CIRCUIT (AMPS)	20
MAX TEMPERATURE SET POINT	240°C
TIME TO RECYCLE	8-10 HOURS
TANK CAPACITY	6.6 US GAL (25L)
LID GASKET	VITON
SHIPPING DIMENSIONS (WDH")	30 X 19 X 45
WEIGHT (LB/KG)	175/80

*Note on voltage:

Operating the unit at a lower voltage (eg: 208V) may result in reduced performance.

SOLVENT REQUIREMENTS

Dirty solvent to be distilled must meet **each requirement** described below. Be sure to read the MSDS (Material Solvent Data Sheet) on the properties of the pure solvent to be recycled.

- The BP (Boiling Point) of the dirty solvent must be less than 240°C (464°F). BP increases with greater contamination. **Note:** Recycle recently contaminated solvent only. Standing solvent can become acidic over time.
- The auto-ignition temperature of the solvent to be distilled must be higher than 250°C (482°F) for safe operation. **Do not recycle Nitrocellulose. The auto ignition temperature is 135°C (275°F).**

Definitions

Flash Point:

The lowest temperature at which the vapor of a solvent can be made to ignite momentarily in air.

Auto-ignition Temperature (often referred to as "ignition Temperature" or "Ignition Point"):

The temperature at which solvent ignites by itself.

PREPARATION AND SETUP:

- Carefully inspect the shipping carton for any sign of transport damage.
- Carefully remove the unit from the shipping carton.
- Check the unit for damage. **Report any transport damage immediately to the carrier and your vendor. Initiate a freight claim with the carrier.** The manufacturer is not responsible for freight damage.
- Check the Accessory Kit for the parts listed below. If any parts are missing, contact your supplier. Additional consumables and accessories are also listed.
- Level the unit using the adjustable feet and install the Door Handle.

ACCESSORY KIT CONTENTS

Manual
Door Handle & 2 Screws
Lid Gasket
Transfer Hose Kit

INCLUDED PARTS

Debris Pail
Solvent Receiving Pail

LOCATION AND CONNECTION:

This unit is certified for use in non-hazardous locations and hazardous locations Class 1, Division 1 Group D and Class 1, Division 2, Group D.

- **Non-hazardous Location:**

If using a non-hazardous plug, the unit must be located outside of a hazardous location. In a non-hazardous location, we recommend that you use a receptacle located a minimum of 6 feet (185 cm) from the unit and a minimum of 30" (80 cm) from the floor. We also recommend that the unit be located at least 6 feet from any potential source of ignition such as electrical receptacles, switches, pilot lights, fixtures, contacts and similar equipment. To clarify the definition of an appropriate location, contact your local authority. This unit must be connected to the power supply only by a qualified electrician in accordance with the National Electrical Code.

- **Hazardous Location:**

In hazardous locations (Class 1, Division 1, Group D and Class 1, Division 2, Group D), the power cord must be connected to the main power supply by a qualified electrician, in accordance with the National Electrical Code. An explosion proof outlet (receptacle or hard wired) must also be used.

Select a Location That Meets EACH AND EVERY Requirement, Described Below.

- 1) Comply with the instructions in the section: CAUTIONS AND WARNINGS.
- 2) Position the solvent recycler in a location so that there is at least 15 inches (15 cm) of space all around the unit. Ensure that the safety lid and door freely open fully. The unit must be in a location where people or equipment cannot disturb the cable or connection. The cord must be connected directly to the main power supply; an extension cord cannot be used.
- 3) Connect the unit to a dedicated branch circuit.

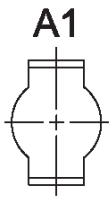
Connections for Transferring Solvent To and From a Drum / Container

Air IN

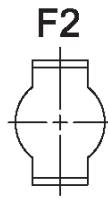
Clean Solvent OUT
From CondenserClean Solvent IN
To Transfer PumpClean Solvent OUT To
External ContainerDirty Solvent
IN

Hand tighten all connections.

Air Supply:

Attach a suitable Quick Coupling Air Supply Fitting (not supplied).

OPERATING PROCEDURES

Wear protective clothing in accordance with local safety and environmental regulations. Use face goggles and gloves as a minimum. Use an apron and respirator if required.

Summary of Operating Steps:

- 1) Open the Safety Cover and Tank Lid
- 2) Transfer Solvent to the Recycler Tank
- 3) Position the Solvent Receiving Pail and the Debris Pail
- 4) Run SETUP to program distillation conditions
- 5) Recycling
- 6) Finish Recycling
- 7) Transfer clean solvent
- 8) Remove debris
- 9) Clean Distillation Tank and Lid Surface
- 10) Inspect Lid Gasket, Remove and Replace if necessary

Each Step is described in detail below.

1) Open the Safety Cover and Tank Lid

- Open the safety cover.
- Open the inner lid by releasing the Lid Clamp.

PULL UP TO OPEN. PUSH DOWN TO LOCK

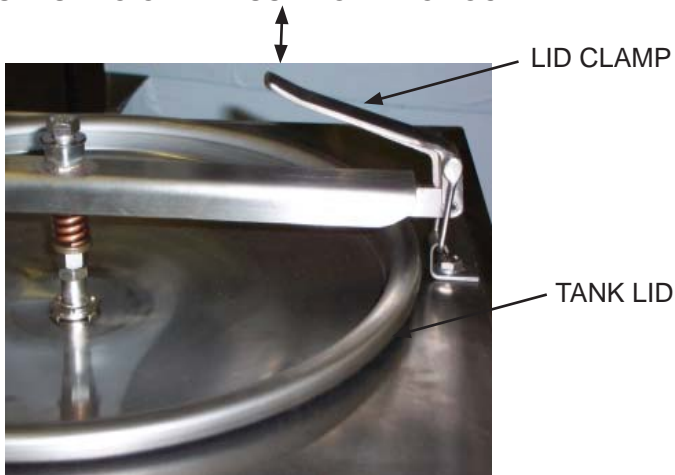

2) Transfer Solvent To the Recycler Tank

Verify that the solvent to be recycled complies with the requirements described in the section, Solvent Requirements. Solvent can be put into the Distillation Tank by hand or by using the Transfer Hoses and built-in Transfer System.

- Open the Transfer Valve by turning the handle counter-clockwise 90°.
- Turn the Filling Timer knob clockwise fully. Dirty solvent will flow from the Transfer Port into the Distillation Tank and stop when the timer runs out.
- Close the Transfer Valve by turning the handle clockwise 90°.
- Close the tank Lid, lock down the Lid Clamp and close the safety Cover.

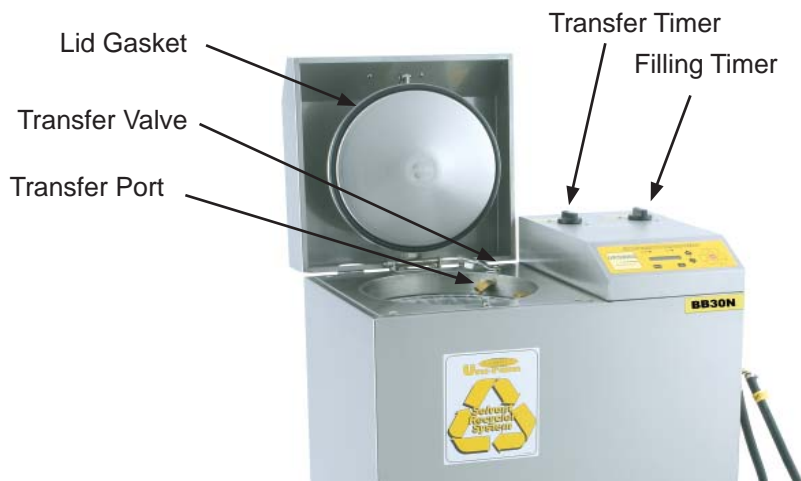

3) Position the Solvent Receiving Pail and the Debris Pail

The Solvent Receiving Pail (plastic) and the metal Debris Pail are shipped together inside the unit. Place the Solvent Receiving Pail outside the unit and the Debris Pail inside. Connect the transfer hoses according to the Connection Diagram.

4) To program distillation conditions, run SETUP

This unit has an enhanced computer controller that allows adjustments to the following: temperature set point, power percentage, bake time and shut-off time. These settings are adjusted using the User Menu displayed on the LCD screen (see following page).

Conditions to consider before starting Setup:

Minimize Temperature Set Point

Select the lowest Temperature Set Point that recycles the solvent so that there is no residue left in the Distillation Tank.

Estimate Boiling Point

Add 40°C (100°F) to the boiling point of the pure solvent as shown on the MSDS (Material Safety Data Sheet) or another reliable source.

Recycle more often

The boiling point of the waste solvent mixture increases as it gets dirtier. To reduce the boiling point, recycle more often.

SETUP MODE

To change settings, enter Setup Mode: while pressing SETUP, press START. "SET-UP MODE" is displayed. **To change the temperature units from °C to °F, press and hold the + and - keys together for 2 seconds.**

STEP	SETTING	ADJUST	ACCEPT	DESCRIPTION
1	SET-PT = XXX°C (°F)	+ OR -	OK	To choose a SET POINT, look up the solvent's BP (boiling point (MSDS, online etc) and add about 40°C (100°F).
2	POWER = XXX%	+ OR -	OK	If boiling is too vigorous due to one or more of the following conditions, decrease POWER by one increment or more. <ul style="list-style-type: none"> • vapour leaks at the Lid Gasket • recycled solvent comes out too hot • waste material is carried into the recycled solvent Otherwise, use 100%.
3	SHUT-OFF = AUTO**	+ OR -	OK	If too much solvent remains in the Distillation Tank after recycling and the problems in the Troubleshooting Guide have been ruled out, over-ride the AUTO SHUT-OFF and manually select a heating time (eg: 4 hours). The heater will stay on for this amount of time and then cooling will begin.
4	BAKE TIME = XXM	+ OR -	OK	Only available when SHUT-OFF = AUTO. Increase if residue (puck) is too wet.
**WARNING: SHUT-OFF TIME MUST NOT BE SET TO MORE THAN 8 HOURS MAXIMUM				

5) Recycling

On first power up and on RESET, the Display Panel shows the Software Version, then: "READY S.P. = XXX°C" (S.P. = SET POINT). When Setup is complete and START has been pressed, the "HEAT" light comes on and the recycling process begins. During the boiling phase, 3 temperatures will alternate on the Display: "SET-PT", "TANK" and "VAPOR EX." When the boiling phase is complete, "COOLING" will be displayed, followed by "READY S.P. = XXX°C". To cancel the cycle, press the "STOP" key.

6) Finish Recycling CAUTION: DO NOT OPEN LID UNTIL COOLING IS COMPLETE

The clean, recycled solvent is available for use when the display shows "READY S.P. = XXX°C". After the clean solvent is transferred, the unit will be ready for another cycle.

Note: during the cooling phase, the display will show "COOLING T = XXX°C" (T = TEMPERATURE) and the fan may still be running; this is normal as it continues to run until the temperature drops below 50°C.

7) Transfer Clean Solvent

Turn the Transfer Timer knob clockwise fully. The clean solvent will flow out of the Solvent Receiving Pail into either a free-standing, external container or the Clean Solvent Pail of a Spray Gun Cleaner. The transfer will stop when the timer runs out.

8) Remove Debris:

Make sure the Debris Pail is in place inside the cabinet and Turn the Drain Valve Handle to release the waste material into the pail. Dispose of the waste according to local regulations.

NOTE: If the bag sticks to the bottom of the tank, turn the recycler on for 5 minutes to loosen the bag from the bottom of the tank, then lift the bag out while the bag is warm.

9) Clean Distillation Tank and Lid Surface

Distillation Tank:

Wipe inside the Tank with a cloth.

Remove any remaining debris from the Distillation Tank using if necessary, plastic or wooden tools (not supplied). Do not clean with abrasive or hard metal instruments that can damage the tank. The warranty does not cover such damage.

Note: There will be about 3 oz (80 ml) of solvent remaining in the Distillation Tank after recycling due to condensation. This solvent, if left in the tank, can cause corrosion. Dirt and debris left in the tank can prevent full heat from reaching the dirty solvent during recycling.

Lid Surface:

Use a cloth. Dry and clean the lid and the top of tank where the Lid Gasket sits to extend the life of the Lid Gasket and prevent leakage. Avoid rotating the lid during cleaning. The lid gasket is a wear item.

10) Inspect Lid Gasket, Remove and Replace if necessary as required

Inspect the Lid Gasket for shrinking, hardness and cuts. The Lid Gasket is a wear item as it is exposed to high temperature and solvent vapor during distillation. Damage to the lid gasket will cause solvent to leak.

To remove, open the Safety Cover and Tank Lid. Lift out the old gasket by hand and clean the cavity with a cloth. To Install, place the new gasket in the cavity, rub solvent or soapy water on the gasket to make insertion easier. Press the gasket firmly into the cavity all around.

Note: Keep a spare in stock. One extra is included with the unit.

THEORY OF OPERATION - DISTILLATION PROCESS

Waste solvent consists of the original solvent plus liquid and solid materials picked up during use of the solvent. Recycling separates the original solvent from the waste materials. During the recycling process, the distillation tank fills with dirty solvent and the heating element heats the mixture. The solvent mixture boils and the vapour passes through a cooling condenser where purified, clean solvent, ready for use condenses out. Waste materials in the dirty solvent boil at a temperature substantially above the Temperature Set Point so they remain in the distillation tank for disposal.

Solvent Recycling

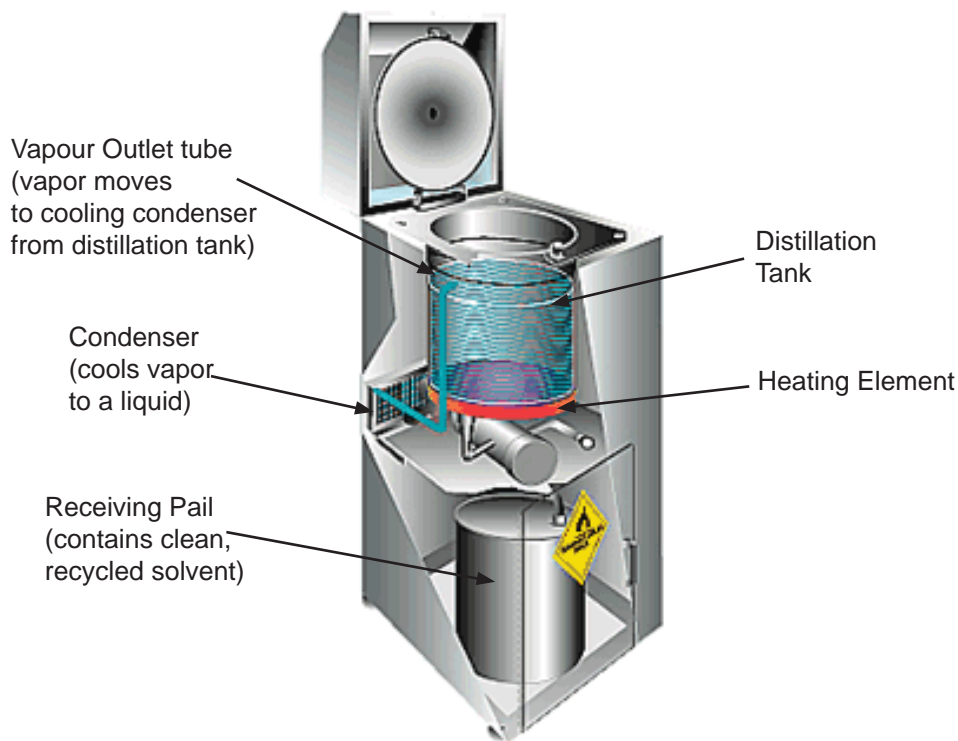

Distillation Cycle

1. Heating starts, temperature rises
2. Vapourization starts
3. Vapourization ends, AUTO SHUT-OFF / BAKE TIME starts (see SETUP)
4. Baking finishes, cooling begins
5. Cooling is complete

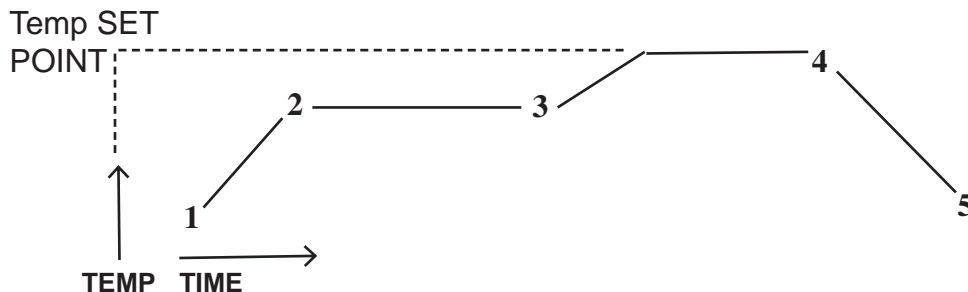

TROUBLE SHOOTING GUIDE

Carry out each action step until a solution is found. If the recommended actions do not solve the problem call Uni-ram Service in North America or contact a qualified Service Technician.

Caution: Disconnect the power supply before conducting maintenance or service.

PROBLEM	CAUSE	ACTION STEPS
Unit is plugged in, power light is off, Display Panel is not working.	Power is not getting to the unit.	Reset breaker or replace fuse. If power is still not getting to the unit, call a Qualified Service Technician. Ensure that the unit is the only device on a circuit with sufficient capacity.
Unit is plugged in, power light is on, Display Panel is not working.	Power board or computer board not functioning.	Call Uni-ram Service
Recycled solvent is not clear	1) The solvent is reacting chemically.	1) Run SETUP and lower the Temperature Set Point.
	2) The solvent flow path is dirty. One cause is overfilling the distillation tank.	2) To clean the path, follow Service Procedure 2 and then recycle 3 gal of clean solvent.
	3) Orange colour due to rust in receiving pail.	3) Place a jar under outlet tube and capture some solvent. If the solvent is clear, replace the pail with a non-corrosive one.
	4) Milky colour due to presence of water.	4) Eliminate source of water in solvent.
Dirty solvent remains in Distillation Tank after recycling Note: about 3 oz (80 ml) of recycled solvent is expected due to condensation.	1) Poor heat transfer due to dirt and debris left in the tank.	1) Clean the tank, replace the Liner Bag, recycle with pure solvent to test. If successful, the problem is due to a dirty tank, debris left in the tank or the solvent is too contaminated. Adjust accordingly. Follow Operating Procedures closely. If the level of contamination is too high, recycle more often.
	2) Boiling point of solvent is above Temperature Set Point.	2) Run SETUP, raise the Temperature Set Point and repeat the recycling operation. The Temperature Set Point should be the BP of pure solvent (as determined from the MSDS or other source) plus 40°C (100°F) to allow for contamination. If the boiling point is above the maximum Temperature Set Point for your model (either 200°C or 240°C), dirty solvent cannot be recycled in this unit.
	3) The Auto Shut Off system is shutting the unit off too soon.	3) Run SETUP and over-ride the auto SHUT-OFF. Select a time period long enough to recycle the solvent. The heater will stay on for this duration. Repeat the recycling operation.
Liner Bag sticks		Turn unit on for 5 minutes and lift out bag while it is still warm.

PROBLEM	CAUSE	ACTION STEPS
Solvent vapor leaks from the Lid Gasket	1) The Lid Gasket has excessive wear as indicated by cracks, shrinkage, hardness etc	1) Replace the Lid Gasket (See Operating Procedure 11).
	2) The Solvent flow path is blocked.	2) Follow Service Procedure 2.
	3) Lid Tension is not adequate	3) Follow Service Procedure 4.
	3) The Lid is not seated correctly.	3) Follow Service Procedure 5.
	4) The temperature SET-PT is too high, resulting in excessively high solvent vapour pressure	4) Run SETUP, reduce the Temperature Set Point and repeat the recycling operation. If successful, continue to recycle using the lower Temperature Set Point. If not, reduce the POWER %.
The computer appears to be operating erratically.	The computer may require re-booting.	Disconnect the power supply for 30 seconds. Restore power and operate unit.
Residue (puck) in Tank is too wet.	1) BAKE TIME is not long enough.	1) Run SETUP and increase the BAKE TIME.
	2) Residue cannot be dried completely due to its composition.	2) None.

TEST MODE

Use this mode as part of your troubleshooting procedures.

1. Make sure Display Panel shows "READY SP = XXX °C".
2. Press and hold the OK key while pressing the + key for about 3 seconds or until the display shows the Model No. and software version followed by "TEST MODE". The testing cycle will begin.

TESTING CYCLE

- The Display shows "TC#1 = XXX °C, TC#2 = XXX°C".
 - Press "OK" to proceed to the next step.
 - The Display shows "FAN ON" for 5 seconds while the Cooling Fan runs.
 - The Display changes to "DO NOT TOUCH KEYS" for 5 seconds while a key check is performed.
 - If the keys are ok, the Display shows "NO KEY STUCK" for 5 seconds.
 - The Display changes to "HEATER TEST ON" for 10 minutes or until the computer detects a 3°C increase in temperature at TC#1, then the Display should change to "HEATER TEST OK".
3. If the display does not show "HEATER TEST OK", there is a problem in the heater circuit such as a defective Heater TRIAC, Heater Element or Fuse.
 4. Press "STOP" to end the test. The Display will return to "READY SP = XXX °C".

ERROR MESSAGES

If an abnormal condition is detected by the unit's Self-diagnostic System, the Display Panel shows one of the following error messages:

MESSAGE	POSSIBLE CAUSE	ACTION
READY TIME OUT	Recycling was not completed within 9 hours and/or dirty solvent remains in the Tank.	If dirty solvent remains in the Tank, see the Troubleshooting Guide.
RESET OCCURRED	The computer has been reset due to a power interruption or drop in voltage during the recycling operation.	Press the "SET-UP" key twice to restore the message: "READY-SP = XXX° C".
CONDSR OVER-HEAT	Over-heating occurred at the Condenser.	The Condenser is dirty or the Fan stopped for another reason (see below). Clean the Condenser. When the Fan Motor has recovered (4-5 min), this message will disappear and normal operation will resume.
CHECK FAN	Appears 10 min after the message above if the problem is a loose fan blade, blown fuse (F3 or F4) or other fan-related problem. Also appears if the condenser is dirty.	Clean the Condenser. Run TEST MODE to check for defective fan motor. If necessary, check for a loose fan blade or blown fuse (see next section).
CHK HEATER FUSES	Appears if the computer does not detect a rise in tank temperature after 10 minutes.	There may be a short circuit in the Heater circuit causing fuse F3 and/or F4 to blow or poor electrical contact in the Heater circuit. Check circuit condition with a tester. Correct as required.
WARNING! VERY IMPORTANT! IF TRIAC IS FAULTY, DISCONTINUE USE IMMEDIATELY!		
CHK HEATER TRIAC	Short circuit in the TRIAC (a switching transistor that controls heater power, located on the Power Control Board).	To confirm, first disconnect and re-connect the power supply. If the Distillation Tank becomes hot to the touch and both the Heat Light and the Fan Light are off, the TRIAC is defective. Disconnect the power supply immediately and do not use again until the Power Control Board has been replaced.

SERVICE PROCEDURES

1) CLEAN CONDENSER

Remove the screen at the back of the unit that covers the condenser and vacuum the condenser using a brush attachment. Re-install the screen.

2) CLEAR BLOCKED SOLVENT FLOW PATH

CAUTION: WEAR SAFETY GOGGLES.

A blockage in the solvent flow path (Vapour Outlet - Condenser - Solvent Outlet Tube) can cause solvent to leak. To determine the location of the blockage, first check the Solvent Outlet Tube and the Vapour Outlet Fitting for visible signs of blockage or damage. If the problem is not in either of these locations, the Condenser is probably blocked. To clear the condenser, pour some clean solvent into the Vapour Outlet and check if it comes out of the Solvent Outlet Tube. If the blockage persists, blow air at about 30 PSI (2 kg/cm²) into the Vapour Outlet. If the air comes out of the Solvent Outlet Tube, the blockage has been cleared. If not, call for service.

3) REPLACE FUSES

Fuses are located on the Power Control Board inside the explosion proof Motor Housing.

WARNING: DO NOT TRY TO REPLACE A FUSE YOURSELF - CALL FOR SERVICE.

4) INCREASE LID TENSION (BY ADJUSTING THE SPRING BOLT)

CAUTION:

SHOULD BE DONE ONLY AS A LAST RESORT - FIRST CHECK FOR A WORN LID GASKET, A BLOCKAGE IN THE SOLVENT FLOW PATH, LOOSE HINGE BOLTS OR A SET POINT THAT IS TOO HIGH FOR THE SOLVENT BEING RECYCLED.

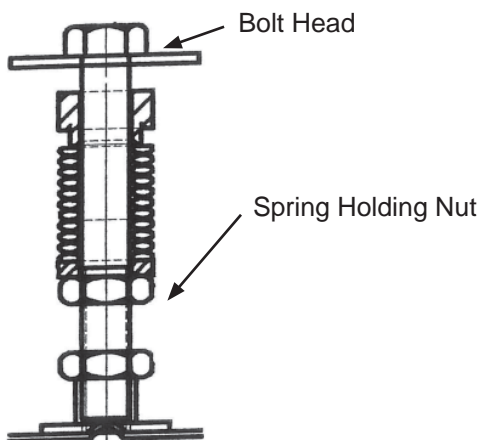

This procedure tightens the Lid by increasing the tension on the spring attached to the Lid Bar Spring Bolt Assembly. The Lid and Bolt Assembly is carefully designed as a Safety Pressure Relief system to prevent a dangerous build up of pressure inside the closed tank. **Do not adjust the Spring Holding Nut by more than 2 full turns maximum.** If 2 full turns do not solve the problem, call for service.

- While holding the Bolt Head with a wrench, turn the Spring Holding Nut no more than a 1/2 turn at a time. Turn in a counter-clockwise direction (as you look down on it).
- After each 1/2 turn, operate the unit normally and check for leaks.

REPLACEMENT PARTS

DESCRIPTION	PART NO.
SAFETY COVER	770-3311
KEYPAD	900-3461
DIAPHRAGM PUMP	UDP4TA
DOOR HANDLE & 2 SCREWS	120-318F & 99-404S
TRANSFER HOSE KIT	
LID GASKET, NEOPRENE	770-2150N
DEBRIS PAIL	920-5500
SOLVENT RECEIVING PAIL	750-710C
TIMER WITH KNOB	115-200/K

Full Product Warranty

These Uni-ram products have been engineered and manufactured to high performance standards. Each unit has been subjected to detailed factory testing before shipment.

This product comes with a one-year full warranty from the date of purchase. Uni-ram Corporation reserves the right to repair or replace the unit, free of charge, to the original purchaser if a part is found to be defective in material or workmanship as determined by factory service personnel. The items listed below under "Conditions of Warranty" as consumables are not covered.

Uni-ram reserves the right to direct the customer to ship the unit collect to the Uni-ram factory or to an approved Service Center for repair using the Uni-ram Return Goods Procedure or to repair the unit on-site. To prevent damage in transport, the purchaser must ship the unit in the original packaging or use alternate adequate packaging. All units must be shipped clean and free of solvent.

Conditions of Warranty:

As Uni-ram Corporation has no control over the working conditions or circumstances under which the purchaser stores, handles or uses the product, Uni-ram makes no warranty or claim, either expressed or implied with respect to this product's fitness for any purpose or the result to be obtained from its use. This condition applies to the sale of all products and no representative or distributor of Uni-ram Corporation has the authority to waive or change these conditions.

This warranty applies only to the original purchaser and does not apply if the unit has been misused, overloaded, neglected, altered or used for any purpose other than those specified in the operating and installation instructions. Deterioration due to normal wear is not covered by this warranty. Damage due to accident, transportation, fire, floods or acts of God is also not covered. Units whose serial numbers have been altered or removed are not covered. The warranty is invalid if unauthorized abrasives are used in this unit. Unauthorized attempts at self-repair or alterations by the owner also invalidate this warranty. Interior or exterior finishes are not covered by this warranty.

Consumable Items are not covered by this warranty.

This warranty replaces all other warranties expressed or implied by statute or otherwise.

To make a claim, call Uni-ram Service at 1-800-417-9133 and quote the serial number of the unit.

USE ONLY GENUINE UNI-RAM LINER BAGS WHICH ARE 2 MIL THICK, LIGHT BLUE IN COLOUR WITH A SAWTOOTH EDGE AND A 3/16" WELD.

THEY ARE SPECIALLY MANUFACTURED TO BE STRONG, HEAT RESISTANT AND CHEMICAL RESISTANT.

USE OF A NON-UNI-RAM LINER BAG MAY VOID THE WARRANTY.