



OPERATING MANUAL

SOLVENT SPRAY GUN CLEANERS

UG5000E, UG5000DVM AND UG5500E

PATENTS

USA	4,788,836
USA	5,213,117
EUROPE	0300248
SWEDEN	0300248
FRANCE	8110528.0

CANADA
ENGLAND
ITALY
GERMANY
JAPAN

UNI-RAM CORPORATION • ONTARIO • CANADA

Rev 2010-09

CONTENTS

INTRODUCTION3
CAUTIONS AND WARNINGS3
FEATURES AND STRUCTURE OF SPRAY GUN CLEANERS
 FEATURES3
 STRUCTURE OF SPRAY GUN CLEANERS4
SETUP
 INSPECTION5
 LOCATION5
 LEVELING, VENT AND AIR SUPPLY5
 SOLVENT SELECTION6
 SOLVENT PAIL SETUP6
 GROUND WIRE INSTALLATION7

OPERATION
 PRE - CLEAN7
 CLEANING SPRAY GUNS AND CUPS8
 USING THE MANUAL WASH and MANUAL RINSE FEATURES8
 HOSE CLEANING ONLY UG5500E8
 AFTER CLEANING8

DAILY MAINTENANCE
 FILTER PADS AND SCREEN9
 REPLACING SOLVENT9
 TROUBLESHOOTING CHART10-11

TROUBLESHOOTING PROCEDURES12-13

FLOW DIAGRAMS14

REPLACEMENT PARTS15

 ACCESSORIES, CONSUMABLES and OPTIONAL PARTS16

WARRANTY
 EXTENDED WARRANTIES For North American Customers16
 FULL PRODUCT WARRANTY17

INTRODUCTION

Uni-ram holds many patents on designs used in its innovative products. Every machine is rigorously tested for compliance with stringent Quality Assurance standards. Follow the directions in this manual under Setup, Operation and Maintenance in order to operate this machine safely and effectively. Not following these instruction can lead to malfunction or damage to the machine. Follow directions under the section below, Cautions and Warnings and on labels attached to the machine. Ensure that the manual is readily available for the operator at all times. If you have any questions about the operation of this machine, call your distributor or a Uni-Ram Service Engineer.

North America:
Uni-ram Technical Service
1-800-417- 9133
Other Continents:
Contact Your Supplier

CAUTIONS AND WARNINGS

- Always disconnect this machine from power sources before performing maintenance
- Do not smoke or use near open flames, sparks or heat.
- Ground pails and cabinet using supplied grounding wires

FEATURES AND STRUCTURE OF SOLVENT SPRAY GUN CLEANER

UG5000DVM - NO PAILS INCLUDED

UG5000E IS SIMILAR AS UG5000DVM AND PAILS ARE INCLUDED

UG5500E IS SIMILAR AS UG5000E AND HOSE CLEANING IS INCLUDED

FEATURES

COMBINATION OF SOLVENT SPRAY GUN CLEANER UG4000DVM AND UG3000DA

UG4000DVM HAS AUTOMATIC WASH, AUTOMATIC AIR FLUSH, AUTOMATIC SOLVENT RINSE, AUTOMATIC FUME VENTING, MANUAL RINSE W. BRUSH, STAINLESS STEEL TANK AND LID, 2 GUNS CLEANED, 14 JETS, RINSE PUMP AND TWO -19L HDP PAILS

UG3000DA HAS AUTOMATIC WASH, AUTOMATIC AIR FLUSH, FUME VENTING (OPTION), STAINLESS STEEL TANK AND HIGH DOOR LID, 2-GUNS CLEANED, 14 JETS AND ONE 19 L TOP CLOSED HDP PAIL.

STRUCTURE OF SPRAY GUN CLEANERS

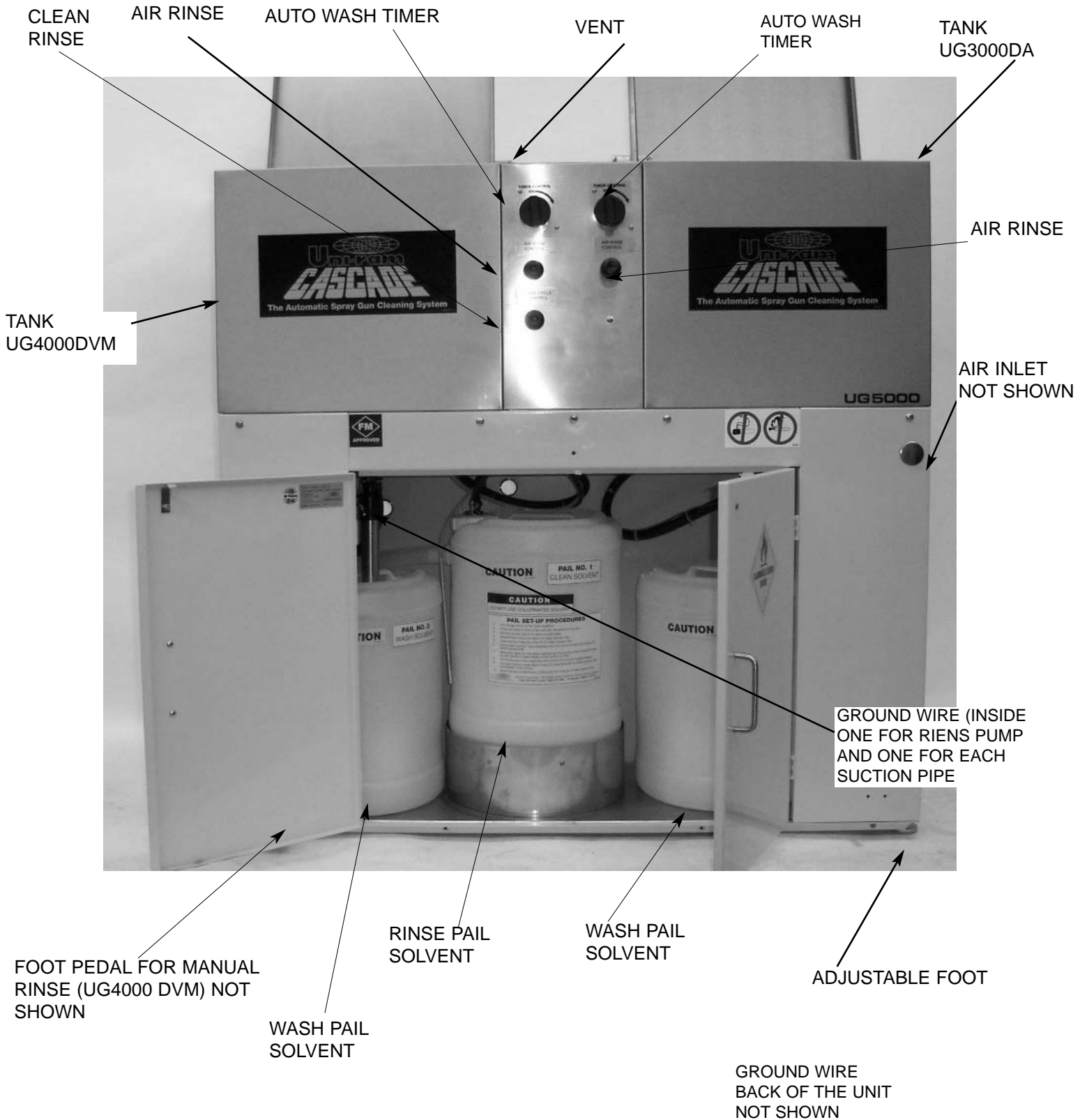

SETUP

INSPECTION

- Inspect the shipping carton for signs of damage. It is your responsibility to report damage to the transport company. Uni-ram Corporation does not accept responsibility for shipping damage once the machine has left our warehouse. Keep the packaging materials until you are sure the machine has not been damaged during shipping.
- Remove the machine from the carton by opening the bottom flaps and sliding the carton up over the machine.
- Make sure the bag of accessories contains the following:
 - Manual
 - Kit-Plug, Guns w. Trigger Lock Springs, 2 pieces (Part No. 140-2340)
 - Nozzle Adapters:
 - 110-430 Push-on, conventional systems only
 - 110-430PPS Push-on, disposable cup or conventional systems

Note: Adapter #780-3530 is installed for use with disposable cup system only
 If any item is missing, contact your supplier.

LOCATION

Position in a well-ventilated area away from sparks, heat and open flames.

LEVELING, VENT AND AIR SUPPLY

- Level the machine using the adjustable legs.
- Attach a vent hose (not supplied) to the vent outlet on top of the machine. The duct system must not be under continuous vacuum.
- To stop or vary the rate of solvent venting from the tank upon opening, use the Vent Control Valve on the side of the unit.
- Remove the cover on the "Air Input" (right side of machine) and attach an air supply adapter (not supplied).

The air supply pressure must be at least 85 PSI and the air must be free from contaminants such as water, dust, rust, tar, grease etc.

To prevent damage to the Diaphragm Pump an internal Air Pressure Regulator has been installed to limit the air pressure to precisely 85 PSI. Do not install a second air pressure regulator or use a pressure set below 85 PSI.



SOLVENT SELECTION

The adhesion quality of automotive paint has dramatically improved in recent years. The choice of solvent is critical. Only use good quality solvent that is formulated for your paint and intended for use with automatic spray guns cleaners.

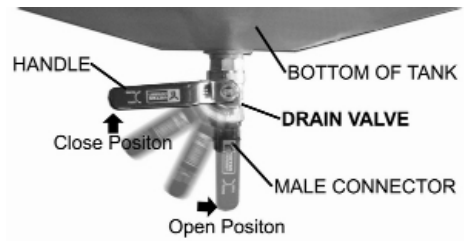

SOLVENT PAIL SETUP

The UG5000E has two tanks. The procedure described below applies to UG4000VM and UG3000DA tanks.

Drain Valve

- Open the door to the base cabinet
- Move the Drain Valve handle to the "closed" (horizontal) position if it is not already there. See picture.
- Two 5-Gal (19 L) HDP round top closed pails of solvent are required for UG4000VM, one full rinse pail and one containing 3 Gal. wash pail. Place the pails in front of the machine, full pail in the middle position and the the other pail on the outside position.
- One 5-Gal (19 L) HDP round top closed pail of solvent is required for UG3000DA. Place the pail in front right of the machine(UG3000DA).
- Inside the cabinet you will see two pipes strapped together, the Suction Pipe and the Rinse Pump. Cut the strap holding them together. Do not cut the other straps holding the black and blue tubes. The Suction Pipe is shown in the section, Replacement Parts.
- Inside right the cabinet you will see the Suction Pipe disconnect it from valve by pushing the gray button and bring the suction pipe out side of the cabinet. The Suction Pipe is shown in the Replacement Parts section.(UG3000DA)
- Disconnect the Suction Pipe from the Drain Valve by pushing the gray button and bring both the suction pipe and the rinse pump outside of the cabinet.(UG4000DVM)
- Insert the Rinse Pump into the full pail in the middle position and the Suction Pipe left into the pail with 3 Gal on the outside.Suction pipe right into the full pail right side. The tube must be inserted through the lid of the left (wash) pail. Models with a Manual Rinse feature have another tube which needs to be inserted through the small hole of the middle (rinse) pail.
- Move the wash pails into the cabinet and re-connect the Suction Pipes of the left and right pails to the Drain Valves respectively.
- Move the rinse pail into middle of the cabinet now.



GROUND WIRE INSTALLATION

Four ground wires are provided to discharge static electricity. To work properly, all must be installed correctly. Connect one ground wire at the back of the cabinet to an external grounded object. 2nd ground wire is connected to suction pipe left(UG4000DVM), 3rd connected to rinse pump and 4th one connected to suction pipe right (UG3000DA).

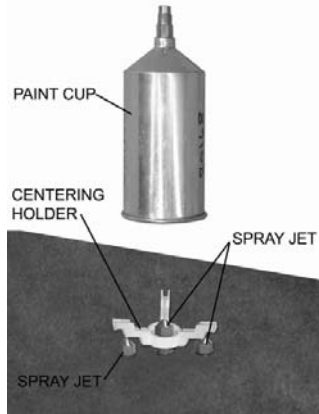
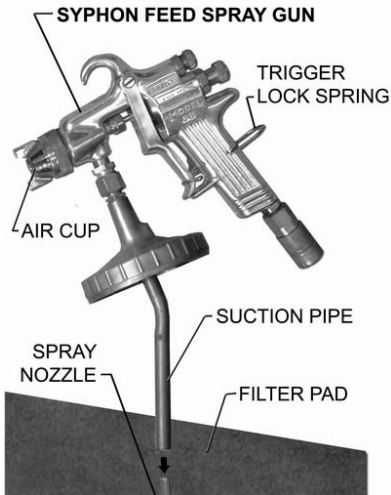
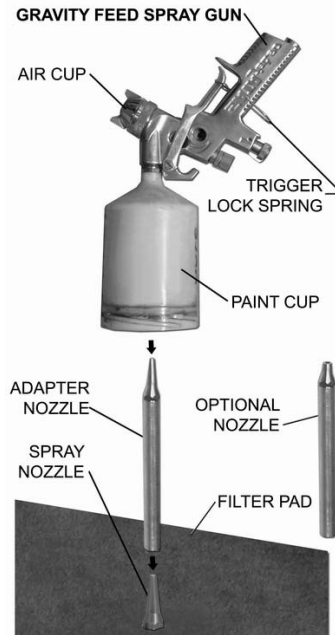
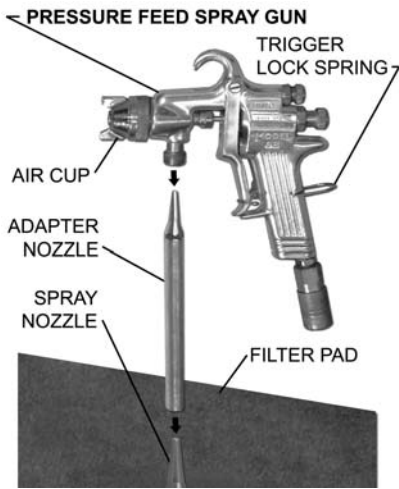

OPERATION

UG4000DVM AND UG3000DA

PRE - CLEAN

- Disconnect the spray gun from the air hose. Pour paint from the cup (when present) into a 5 gallon pail (not supplied).
- Rinse cup with solvent and pour into the same 5 gallon pail for later disposal or recycling.

CLEANING SPRAY GUNS AND CUPS

- Loosen the air cap of the spray gun two full turns.
 - Lock the trigger in the open position with the Trigger Lock Spring.
 - To prevent liquid from entering the air passgae during automatic cleaning, insert the white plastic Air Passage Plug into the Spray Gun's air inlet. If the air inlet has a male threaded connector instead of a quick connect use the knurled nut attached to the Trigger Clamp (included).
- 
- Place spray guns facing corner jets. Placement depends on **type of spray gun**. See pictures below. Place cups onto the low spray jets and cup holders.
 - Close the lid and turn the "Auto Wash Timer" knob clockwise to start cleaning. The cleaning cycle takes about 60 seconds
 - Push and hold the "Air Rinse" button for about 3 second to air-rinse the guns.
 - Push and hold the "Clean Rinse" button for about 5 seconds to rinse guns with clean solvent. This will send a pre-set amount of clean solvent (100 cc) through the jets. Wait 30 seconds for the Rinse Pump to fully recharge before repeating.

The solvent flow per clean-rinse cycle is limited to 100 cc to minimize consumption. This quantity is usually sufficient to clean the inside pasages of the spray guns.

USING THE MANUAL WASH and MANUAL RINSE FEATURES

- For models with manual wash brush, open the lid and step on the foot pedal (left side). A dedicated pump delivers wash solvent through the brush.
- For models with the Manual Rinse feature, open the lid and step on the foot pedal (right pedal on two-pedal models). Clean solvent is delivered through the brush.

Solvent flow through the rinse brush is limited to minimize clean solvent consumption.

HOSE CLEANING ONLY UG5500E

- Models with this feature to clean a paint feeder hose up to 100 feet (30m) long. Connect the to the two fittings, one on the front and one on the right side. Rotate the "Mode Selector" to the right (Horizontal position) and turn the Timer knob clockwise to start the automatic cleaning cycle.
- To air rinse the hose, push and hold the "Air Rinse" button
- To rinse the hose with the clean solven, push and hold the "Clean Rinse" button for about 5 seconds. This will use about 100 cc of clean solvent. Wait 30 seconds for the Rinse Pump to fully recharge before repeating.
- Disconnect the hose.

AFTER CLEANING

- Remove the guns and cups from the tank and wipe them dry. Do not store spray guns in the tank.

DAILY MAINTENANCE

FILTER PADS AND SCREEN

- Inspect the filter pad located in the tank of the gun cleaner(UG4000VM) and clean it if there is a build up of paint debris. Clean by removing the filter pad and washing away paint particles with clean solvent. Replace the filter pad when damaged or when solvent cannot drain.
- Inspect the screen, located below the filter pad and clean when necessary(UG4000VM).
- If a Moisture Filter (not supplied) is used, drain and flush the Moisture Filter by allowing air under pressure to flow through it.
Replace cap.

REPLACING SOLVENT BOTH SYSTEMS

- Disconnect the Suction Pipe from the Drain Valve and remove the pipe from the pail. Move the pail out of the cabinet and recycle or dispose of the wash solvent.
- Remove the Rinse Pump from the other pail, move the pail out of the cabinet and locate on left side for use with the suction pipe.
- Place a new, full-pail of clean solvent on the right side in front of the cabinet.
- Insert the Rinse Pump into the full pail on the right and the Suction Pipe into the half-full pail on the left. Models with a Manual Wash brush also have a tube to supply the brush. The tube must be inserted through the lid of the left (wash) pail. Models with a Manual Rinse feature have another tube which needs to be inserted through the lid of the right (rinse) pail.
- Move the pails into the cabinet and re-connect the Suction Pipe of the left and right pails to the Drain Valve.

TROUBLESHOOTING CHART

SYMPTOM	REASON	CORRECTIVE ACTION
<p>WASH SOLVENT OR WATER DOES NOT FLOW AND PUMP MAKES A NORMAL PUMPING SOUND</p>	<ul style="list-style-type: none"> • Drain valve closed • Solvent or water level too low • Paint debris in pump • Blockage in solvent line 	<p>After Each Step Below, Turn Timer(Solvent) or Foot pedal(Water). If solvent does not flow, carry out next step.</p> <ul style="list-style-type: none"> • Open drain valve(UG4000) (put in verticle position), if not already open • Check wash solvent level. Add solvent if less than 1/2 full. • Follow Procedure 1, Blocked Fluid Passage in Diaphragm Pump. • Follow Procedure 4, Blocked Passage in Solvent Line
<p>WASH SOLVENT OR WATER DOES NOT FLOW AND PUMP MAKES A HISSING SOUND</p>	<ul style="list-style-type: none"> • Water in air line causes pump to stall 	<ul style="list-style-type: none"> • Follow Procedure 2, Blockage in Air Passage in Diaphragm Pump
<p>WASH SOLVENT OR WATER DOES NOT FLOW AND PUMP DOES NOT MAKE A SOUND</p>	<ul style="list-style-type: none"> • Pump leaks • Blockage in air passage 	<ul style="list-style-type: none"> • Replace pump • Follow Procedure 3, Blocked Passage in Air Line
<p>PUMP DOES NOT STOP UNLESS TIMER IS TURNED BY HAND OR AIR IS SHUT OFF</p>	<ul style="list-style-type: none"> • Defective timer (UG4000VM) 	<ul style="list-style-type: none"> • Replace timer
<p>TIMER KNOB SPINS BACK WHEN TURNED</p>	<ul style="list-style-type: none"> • Defective timer 	<ul style="list-style-type: none"> • Replace timer
<p>INSIDE WALL OF TANK IS COATED WITH PAINT EVEN THOUGH OPERATOR MAINTAINS TANK</p>	<ul style="list-style-type: none"> • Solvent lacks cleaning strength 	<ul style="list-style-type: none"> • Replace solvent with solvent that is formulated for type of paint used and for use with automatic spray gun cleaning

TROUBLESHOOTING CHART

SYMPTOM	REASON	CORRECTIVE ACTION
CLEANING PROBLEMS		
<p>GUNS NOT CLEAN, PUMP WORKING, SOLVENT OR WATER FLOW NORMAL</p>	<ul style="list-style-type: none"> • Trigger not locked in open position • Spray gun is not properly installed on to nozzle • Incompatible solvent • Low pressure in air supply • Plugged jets 	<p>After Each Step Below, Turn Timer. If guns are not clean, carry out next step.</p> <ul style="list-style-type: none"> • Use Trigger Lock Spring • Re-install with proper adapter • Replace incompatible solvent with solvent formulated for type of paint used and for Automatic Spray Gun Cleaners. • Increase air pressure to a minimum of 85 PSI • Remove and clean by blowing air through the jets. If not successful, replace.
<p>GUNS NOT CLEAN, WASH SOLVENT IS MILKY WHITE</p>	<ul style="list-style-type: none"> • Wash solvent is contaminated with water 	<ul style="list-style-type: none"> • Replace or recycle wash solvent
<p>CLEAN RINSE DOES NOT WORK</p>	<ul style="list-style-type: none"> • Not enough solvent in clean rinse pail (right side) • Rinse Pump is leaking from a crack caused by corrosion due to acidic or chlorine-contaminated solvent • Clean Rinse Air Valve is defective 	<ul style="list-style-type: none"> • See Section "REPLACING SOLVENT" • Replace rinse pump • Follow Procedure 3, "Blocked Passage in Air Line" for air rinse valve only.
<p>CLEAN RINSE IS DIRTY</p>	<ul style="list-style-type: none"> • Faulty Combination Valve 	<ul style="list-style-type: none"> • Replace Combination Valve.

TROUBLESHOOTING PROCEDURES

PROCEDURE 1

Blocked Fluid Passage In Diaphragm Pump

If the pump sounds like it is working but liquid does not flow, clear the fluid passage as follows:

- Remove suction tube from the pail and blow air at 85 PSI into the INLET Solvent Hose (see diagram). Step on foot pedal. This procedure may have to be repeated several times. If this procedure does not help, blow some water into the suction hose using a spray gun, wait one minute and step on foot pedal. This procedure may have to be repeated several times. If this procedure does not work, the pump must be replaced.

If you need to replace the pump call your local dealer. The warranty on the diaphragm pump is two years from date of purchase.



This procedure will also clear a blockage in the fluid line for the wash gun.

PROCEDURE 2

Blocked Air Passage In Diaphragm Pump

If there is a steady hissing sound and the pump is not cycling, the spool valve has stalled due to a blocked air passage. Follow the procedure below to clear the blockage.

- Connect a blow gun to an 85 PSI source. Locate the blue hose that extends from the air exhaust port of the diaphragm pump. Use a blow gun to blow air into the open end of this hose. Turn timer. If the procedure is successful, the pump will start working. The procedure may have to be repeated several times. If this procedure does not work, replace the pump.
- Cause: Contaminants in the air supply (water, oil, solid particles etc)
- Preventative Action: If necessary, install an Airline (Moisture) Filter.

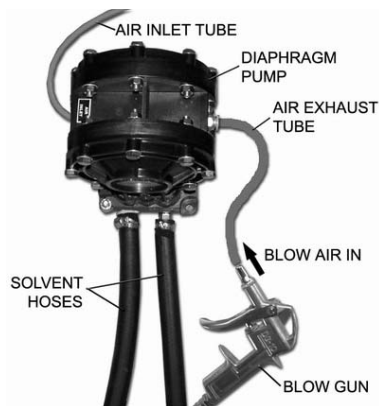

PROCEDURE 3

Blocked Passage in Air Line

The components in the air line are the diaphragm pump, air valve, foot pedal, 3-way ball valve and regulator. See the Flow Diagram and the section: Replacement Parts.

To troubleshoot a component:

- 1) Disconnect the air line to the component using the quick disconnect.
- 2) Step on foot pedal and check for presence of positive air pressure in the air line. If there is ample positive air pressure, replace the component.

If air pressure is absent, there is a faulty component upstream. Reconnect the air line and check the operation of the next component upstream by following steps 1 and 2 above.

FLOW DIAGRAM

Shows the flow of solvent and compressed air.

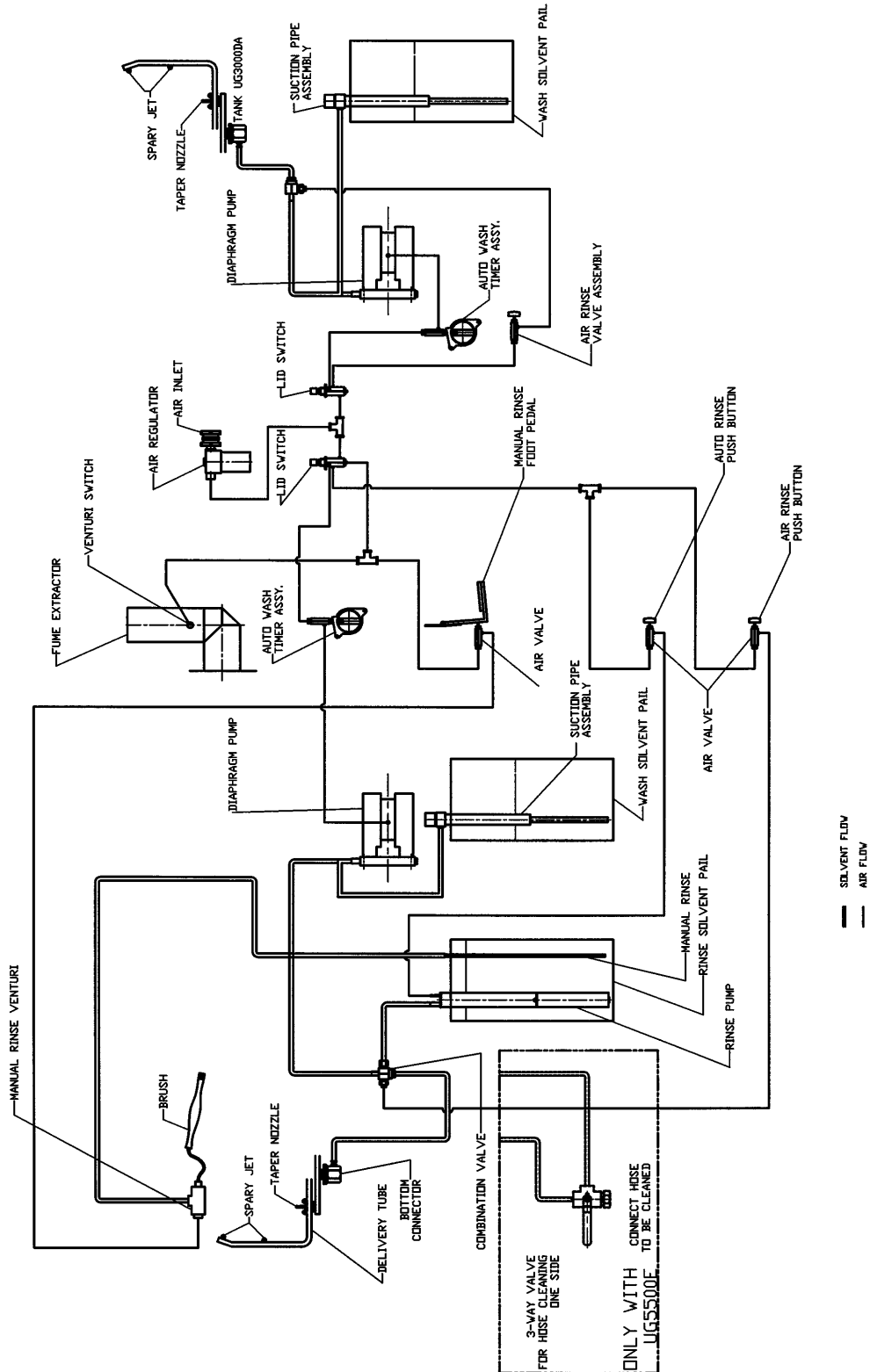

**REPLACEMENT PARTS
UG5000E SERIES**

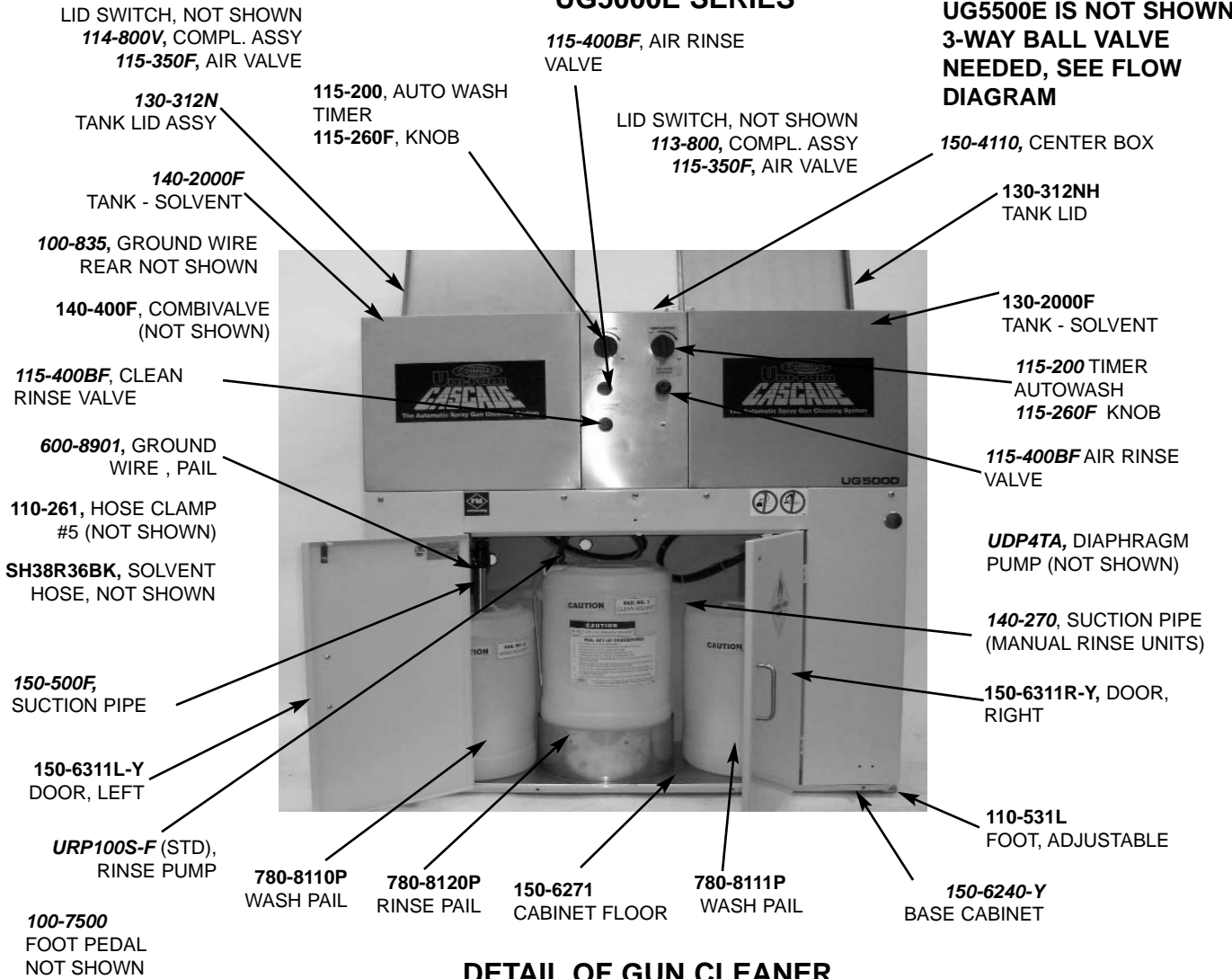

DETAIL OF TANK
PROVIDED BELOW
**UG5500E IS NOT SHOWN
3-WAY BALL VALVE
NEEDED, SEE FLOW
DIAGRAM**

**DETAIL OF GUN CLEANER
TANK - SOLVENT**

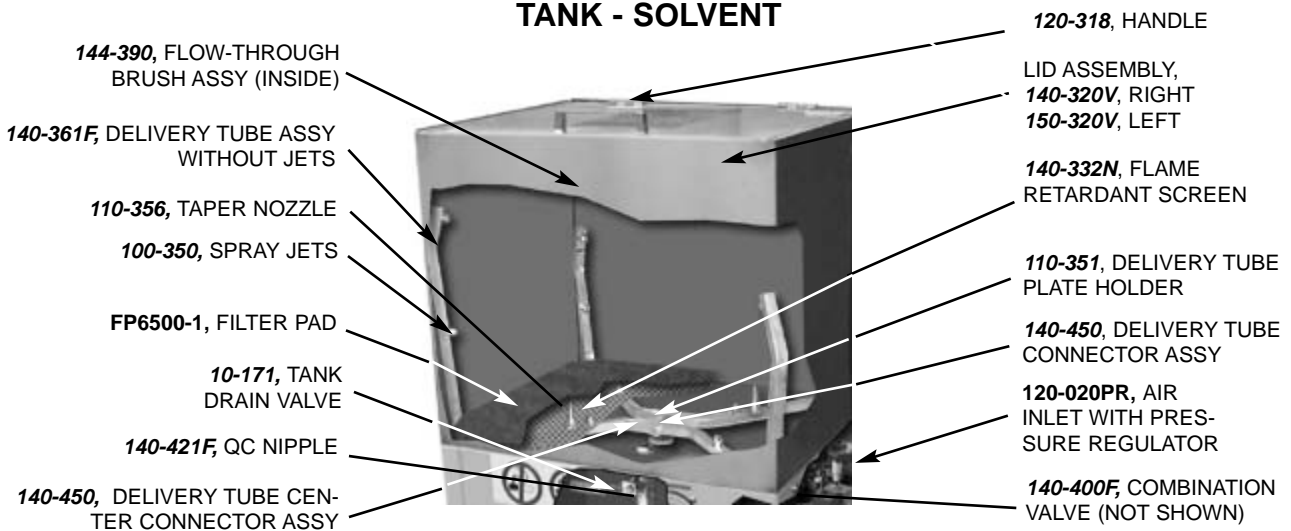

ACCESSORIES, CONSUMABLES and OPTIONAL PARTS

Part No.	Description
110-430	Nozzle Adapter, Push On, Conventional Systems Only
110-430PPS	Nozzle Adapter, Push On, Disposable and Conventional Systems
780-3530	Nozzle Adapter, Disposable Cup Systems Only
100-413F	Paint Cap Holder
115-200/K	Mechanical Timer Assembly, 5 minutes
140-230	Air Passage Plug
140-2340	Trigger Clamp & Plug Kit, 4 pieces
140-340S	Rotating Spray Jet Assembly
144-390	Flow-Through Brush Assembly
144-397	Hose for Flow-Through Brush
100-835	Ground Wire for Gun Cleaner, 18G, Green, 4 FT
600-8901	Ground Wire for Pail
FP6500-10	Filter Pad, Regular, 13.75" x 17.5", Pkg of 10
KIT-MW4000	Manual Wash Kit, Upgrade DV to DVM

EXTENDED WARRANTIES For North American Customers

An extended warranty may be purchased within 3 months from the date of purchase. There are two types of warranty:

- 1) parts
- 2) parts and labour

The warranty period is 2, 3 or 4 years.

If you would like to purchase an extended warranty call Uni-ram at:

Canada	1-800-417-9133
USA	1-800-735-4331

Full Product Warranty



These Uni-ram products have been engineered and manufactured to high performance standards. Each unit has been subjected to detailed factory testing before shipment.

This product comes with a one-year full warranty from the date of purchase. Uni-ram Corporation reserves the right to repair or replace the unit, free of charge, to the original purchaser if a part is found to be defective in material or workmanship as determined by factory service personnel. The items listed below under "Conditions of Warranty" as consumables are not covered.

Uni-ram reserves the right to direct the customer to ship the unit collect to the Uni-ram factory or to an approved Service Center for repair using the Uni-ram Return Goods Procedure or to repair the unit on-site. To prevent damage in transport, the purchaser must ship the unit in the original packaging or use alternate adequate packaging. **All units must be shipped clean and free of solvent.**

Diaphragm Pump:

We are pleased to advise that the warranty on the diaphragm pump, the heart of the spray gun cleaner, comes with a 2 year replacement warranty. If, in the unlikely event your diaphragm pump fails during the first two years of service, call Uni-ram Service at 1-800-417-9133. We will send you a new pump free of charge and arrange for the return of your original pump.

Conditions of Warranty:

As Uni-ram Corporation has no control over the working conditions or circumstances under which the purchaser stores, handles or uses the product, Uni-ram makes no warranty or claim, either expressed or implied with respect to this product's fitness for any purpose or the result to be obtained from its use. This condition applies to the sale of all products and no representative or distributor of Uni-ram Corporation has the authority to waive or change these conditions.

This warranty applies only to the original purchaser and does not apply if the unit has been misused, overloaded, neglected, altered or used for any purpose other than those specified in the operating and installation instructions. Deterioration due to normal wear is not covered by this warranty. Damage due to accident, transportation, fire, floods or acts of God is also not covered. Units whose serial numbers have been altered or removed are not covered. The warranty is invalid if unauthorized chemicals as noted in the manual or solvents with acid content are used in this unit. Unauthorized attempts at self-repair or alterations by the owner also invalidate this warranty. Interior or exterior finishes are not covered by this warranty.

Consumable Items are not covered by this warranty (eg: gaskets, screens, bags, filters, nozzles and air jets).

This warranty replaces all other warranties expressed or implied by statute or otherwise.

To make a claim, call Uni-ram Service at 1-800-417-9133 and quote the serial number of the unit.